

**MODEL 3377**  
**32 CHANNEL CAMAC TDC**



Revised  
January 1997

(ECO 1101)



**Corporate Headquarters**

700 Chestnut Ridge Road  
Chestnut Ridge, New York 10977-6499  
Tel: (914) 578-6013 Fax: (914) 578-5984  
E-mail: [lrs\\_support@lecroy.com](mailto:lrs_support@lecroy.com)

## CE CONFORMITY

---

### CONDITIONS FOR CE CONFORMITY

Since this product is a subassembly, it is the responsibility of the end user, acting as the system integrator, to ensure that the overall system is CE compliant. This product was demonstrated to meet CE conformity using a CE compliant crate housed in an EMI/RFI shielded enclosure. It is strongly recommended that the system integrator establish these same conditions.

## CAUTION

---

**COOLING**

It is imperative that the Model 3377 TDC be well cooled. Be sure fans move sufficient air to maintain exhaust air temperature at less than 50° C.

**INSTALLATION**

Crate power should be turned off during insertion or removal of modules in accordance with the CAMAC specification.

**SPECIFICATIONS**

The information contained in this manual is subject to change without notice. The reference for product specification is the Technical Data Sheet effective at the time of purchase.

**ELECTROSTATIC  
SENSITIVITY**

While measures have been taken to protect the MTD133 ASIC from electrostatic damage, it is still imperative to follow anti-static procedures when handling this CMOS device. Removal of the MTD133 from its socket may void the warranty.

# TABLE OF CONTENTS

<b>1. General Information</b>	
Purpose	9
Unpacking and Inspection	9
Warranty	9
Product Assistance	9
Maintenance Agreements	9
Documentation Discrepancies	10
Software Licensing Agreement	10
Service Procedure	10
<b>2. Installation</b>	
General Installation	11
Cables	11
<b>3. Product Description</b>	
Introduction	13
Product Description	13
Specifications	14
Front Panel	14
Displays	15
Inputs and Outputs	15
Control	15
Signal Inputs	16
ECLbus output	16
Rear Panel	16
Standard CAMAC Function Codes	16
<b>4. Operating Instructions</b>	
Programming the Unit for a Different Mode of Operation	19
Operating Modes	20
Mode 0: Common Stop, Single Word Mode	21
Control Registers	21
Maximum Time Range	23
Offset	23
Dead Time	24
Front Panel Clear Input	24
Mode 1: Common Start, Single Word	25
Control Registers	25
Common Start Time Out	27
Dead Time	28
Front Panel Clear	28
Mode 2: Common Stop, double word	29
Control Registers	29
Maximum time range	31
Dead Time	31
Front Panel Clear Input	31
Mode 3: Common Start, Double Word Mode	32
Control Registers	32
Common Start Time out	34
Dead Time	34
Front Panel Clear	34

---

Trigger Outputs	36
Trigger Outputs in the Common Stop Modes	36
Trigger Outputs in the Common Start Modes	37
Readout Modes and Data Formats	38
CAMAC	38
Buffered Mode	38
Unbuffered Mode	38
ECLPORT (FERA) Mode	38
Buffered Mode	38
Unbuffered Mode	38
FERA Compatibility	38
Standard 4300B FERA Behavior	38
Modified Model 3377 FERA Behavior	39
4300 Compatible Mode	39
Fast FERA Mode	40
Data Formats	40
Single Word Format	40
Double Word Format	40
Suppressing the Header	41
Example 3377 Programming Sequence	42
<b>5. Theory of Operation</b>	
Time Measurements	43
Control and Readout	43
Event Buffer Memory	44
CAMAC Interface	44
ECL Port	44
Trigger Outputs	44
Support Circuits	44
<b>6. Additional Information</b>	
Testing the Model 3377	45
Extending the Time Range	46
LabView™ Support	47
<b>7. Index</b>	49

## GENERAL INFORMATION

### PURPOSE

This manual is intended to provide information regarding the installation and operation of the LeCroy Model 3377 Time-to-Digital Converter.

### UNPACKING AND INSPECTION

It is recommended that the shipment be thoroughly inspected immediately upon delivery. All material in the container should be checked against the enclosed Packing List and shortages reported promptly. If the shipment is damaged in any way, please notify the Customer Service Department or the local field service office. If the damage is due to mishandling during shipment, you may be requested to assist in contacting the carrier in filing a damage claim.

### WARRANTY

LeCroy warrants its instrument products to operate within specifications under normal use and service for a period of one year from the date of shipment. Component products, replacement parts, and repairs are warranted for 90 days. This warranty extends only to the original purchaser. Software is thoroughly tested, but is supplied "as is" with no warranty of any kind covering detailed performance. Accessory products not manufactured by LeCroy are covered by the original equipment manufacturers' warranty only.

In exercising this warranty, LeCroy will repair or, at its option, replace any product returned to the Customer Service Department or an authorized service facility within the warranty period, provided that the warrantor's examination discloses that the product is defective due to workmanship or materials and has not been caused by misuse, neglect, accident or abnormal conditions or operations.

The purchaser is responsible for the transportation and insurance charges arising from the return of products to the servicing facility. LeCroy will return all in-warranty products with transportation prepaid.

This warranty is in lieu of all other warranties, express or implied, including but not limited to any implied warranty of merchantability, fitness, or adequacy for any particular purpose or use. LeCroy shall not be liable for any special, incidental, or consequential damages, whether in contract, or otherwise. **PRODUCT ASSISTANCE** Answers to questions concerning installation, calibration, and use of LeCroy equipment are available from the Customer Service Department, 700 Chestnut Ridge Road, Chestnut Ridge, New York, 10977-6499, (914) 578-6030.

### MAINTENANCE AGREEMENTS

LeCroy offers a selection of customer support services. For example, Maintenance Agreements provide extended warranty that allows the customer to budget maintenance costs after the initial warranty has expired. Other services such as installation, training, on-site repair, and addition of engineering improvements are available through specific Supplemental Support Agreements. Please contact the Customer Service Department.

### DOCUMENTATION

---

**DISCREPANCIES**

LeCroy is committed to providing state-of-the-art instrumentation and is continually refining and improving the performance of its products. While physical modifications can be implemented quite rapidly, the corrected documentation frequently requires more time to produce. Consequently, this manual may not agree in every detail with the accompanying product and the schematics in the Service Documentation. There may be small discrepancies in the values of components for the purposes of pulse shape, timing, offset, etc., and, occasionally, minor logic changes. Where any such inconsistencies exist, please be assured that the unit is correct and incorporates the most up-to-date circuitry.

**SOFTWARE LICENSING AGREEMENT**

Software products are licensed for a single machine. Under this license you may:

- Copy the software for backup or modification purposes in support of your use of the software on a single machine.
- Modify the software and/or merge it into another program for your use on a single machine.
- Transfer the software and the license to another party if the other party accepts the terms of this agreement and you relinquish all copies, whether in printed or machine readable form, including all modified or merged versions.

**SERVICE PROCEDURE**

Products requiring maintenance should be returned to the Customer Service Department or authorized service facility. If under warranty, LeCroy will repair or replace the product at no charge. The purchaser is only responsible for the transportation charges arising from return of the goods to the service facility. For all LeCroy products in need of repair after the warranty period, the customer must provide a Purchase Order Number before any inoperative equipment can be repaired or replaced. The customer will be billed for the parts and labor for the repair as well as for shipping. All products returned for repair should be identified by the model and serial numbers and include a description of the defect or failure, name and phone number of the user. In the case of products returned, a Return Authorization Number is required and may be obtained by contacting the Customer Service Department.



# INSTALLATION

## GENERAL INSTALLATION

The LeCroy Model 3377 TDC is intended for use within a standard CAMAC crate, such as the LeCroy Model 8025 CAMAC Crate with 25 slot positions or the Model 8007A with 7 positions. The following voltage sources must be properly connected to the backplane: +24 V, +6 V, -6 V, and -24 V. Each crate must be controlled by either a slave or intelligent controller. The controller must occupy the right-most slot in the crate. Its purpose is to issue CAMAC commands to the modules and transfer information between a computer (or other digital device) and the CAMAC modules. LeCroy offers such crate controllers, including the Model 8901A. The 8901A is a GPIB/CAMAC slave interface that operates as a "Talker/Listener", allowing the crate to act as one GPIB instrument.

With the power off, the 3377 is inserted into one of the slots of the CAMAC crate. The edge connector on the module should mate with the bus connector with modest pressure. The thumb screw located on the lower edge of the card should be engaged and tightened. Note the slot number of the module, as it will later be used for addressing.

## CABLES

The 3377 is designed to use twisted pair cables for the input, output and control signals, single twisted pair cables for the control inputs and 34 wire ribbon cable for the inputs and ECLbus output. Care should be taken to install high quality cables to minimize the effects of noise and crosstalk. There are two types of 34 conductor multiwire cables available, one for short connections using flat ribbon cable and one for longer connections using twist and flat cable.

Suitable cables are available from LeCroy.

- **STP-DC /02/L** - single twisted pair cable for control signals.
- **STC-DC /34/L** - flat multiwire cable for short interconnections.
- **LTC-DC /34-L or DC2 /34-L** - twisted-pair multiwire cable for long interconnection.

All signal inputs are differential ECL and have a balanced 120 ohm termination.

# PRODUCT DESCRIPTION

## INTRODUCTION

The LeCroy CAMAC Model 3377 is a 32-channel Multihit Time-to-Digital Converter (TDC) intended for high rate particle physics experiments. The 500 picosecond digitizing resolution, 32 microsecond maximum full scale, and low dead time make the Model 3377 suitable for a wide range of applications. The Model 3377 can be operated either in Common Start or Common Stop mode with up to 16 measurements (16 edge measurements, leading edge only, or leading and trailing edge) recorded on each channel. The full scale time range is programmable up to 32 microseconds. The eight trigger outputs are programmable, and can be used in either first or second level triggers. The multi event buffer allows up to 31 events to be recorded before readout. The readout is either over the CAMAC dataway, or by a FERA™ compatible high speed ECL port.

## PRODUCT DESCRIPTION

The 32 inputs are differential ECL, with a balanced 120 ohm termination. Either the leading edge or both leading and trailing edge may be recorded, with a double hit resolution of less than 10 nanoseconds. The number of edge measurements recorded per channel is programmable from 1 to 16.

The 3377 can be programmed to operate in either Common Start or Common Stop mode with either single or double data word output format.

The single word format packs 10 data bits (leading edge only, 9 bits if both edges are recorded) into a 16 bit word, for low dead time drift chamber applications. The programmable offset and resolution (500 ps to 4 nsec LSB) allow the time range (255 nanoseconds to 4 microseconds) to be placed as a window anywhere within the 32 microsecond full scale.

The double word format preserves the full 16 bit time data for wide dynamic range applications. The full scale time is programmable in 8 nsec steps up to 32.7 microseconds. The resolution is fixed at 500 picoseconds.

Eight dECL trigger outputs are provided at the rear panel. For trigger purpose only, the input pulses are OR'ed together in groups of four (for example: output 1 is the or channels 0, 1, 2, 3). In Common Stop mode, the trigger outputs are programmable in width and delay, and can be latched at the Stop time. In Common Start mode, the triggers are latched.

The 3377 may be tested using an internal tester (Common Start mode only). The number of pulses and the pulse duration are programmable.

At the end of acquisition (Common Stop or Common Start time out) the data is unloaded from the MTD133s and stored in a multievent FIFO buffer. The dead time is 1.8 microseconds plus 100 nsec per recorded hit (200 nsec per hit when in double word mode).

The readout is by standard CAMAC or by the high speed ECL port. This can occur in background, while the front end is recording data hits. A

header word containing a programmable identification byte precedes the data. This header can be suppressed (programmable) if the module contains no data. The readout is by event, to ensure synchronization of the readout of several modules. The ECL port readout can be as fast as 100 nsec per 16 bit word, and is compatible with existing FERA modules.

The many versatile features of the Model 3377 are provided by a Xilinx programmable gate array chip, which contains the control logic for the board. Changing the mode (Common Start/Stop, single/double word) requires a series of simple CAMAC commands which clear and reprogram the Xilinx gate array with the appropriate firmware from an on board EPROM.

**SPECIFICATIONS**

Please refer to the Module 3377 technical data sheet for a complete summary of the current specifications.

**FRONT PANEL**

The LeCroy Module 3377 TDC front panel provides the user with connectors for system integration and LEDs to assist system debugging. Cables necessary for proper installation can be purchased from LeCroy. See Section 3 for more information regarding cabling.

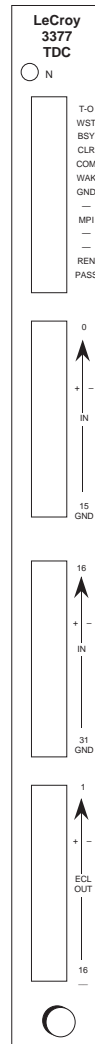

---

## Displays

**N LED:** The only LED on the front panel is an N indicator, which is illuminated whenever the module is addressed.

**Termination LED:** Just behind the front panel, between the lower input connector and the ECL port, is an LED which is only visible when there are no signal cables connected. The control signal terminations and pull down resistors for the control signals and the ECL port are socketed. When several 3377 are bussed together to a 4301 FERA driver, all of the socketed resistors should be removed from each unit, except from the last 3377. The termination LED uses one of the unused resistors in a pull down resistor SIP and is lit when the SIP is installed. When several 3377s are bussed together only the last one should have this LED illuminated.

## Inputs and Outputs

### Control

Below the N LED is a 26 pin header used for ECL port control (WST, WAK, REN, PASS), time out input (T-O), busy output (BSY), clear input (CLR), common input (COM), and measure pause input (MPI).

- **T-O - Timeout input:** A dECL input used to receive an external common start timeout. The rising edge of this input ends acquisition in common start mode. It is OR'ed with the internal time out.
- **WST - Write Strobe:** dECL output indicates when a valid data word is present on the ECLport.
- **BSY - Busy output:** This dECL output indicates the 3377 cannot accept hits. This occurs during the buffering dead time and when the multievent buffer is full.
- **CLR - Clear input:** A dECL input used to fast clear events and abort acquisition or MTD133 readout. The control registers and data from previous events is not affected.
- **COM - Common input:** A dECL input for the common hit. The time measurement is from the rising edge. **Note: In Common Start modes, additional pulses on the COM line arriving before the Common Start timeout will disable acquisition.**
- **WAK - Write Acknowledged:** Input from 4301 or 4302 for FERA interlocked handshake. Indicates that the data has been accepted.
- **GND - Ground**
- **MPI - Measure Pause Interval:** A dECL input for external MPI. This is OR'ed with the internal MPI. The effect is to hold off unloading of the data from the MTD133s until the end of MPI.
- **REN - Readout Enable:** dECL Input that enables the ECLbus drivers and allows one event to be read out. REN must cycle false and then true again for the next event to be read out.
- **PASS:** A dECL output indicating that the last valid data word in the current event has been read out.

---

**Signal Inputs**

Two 34 pin headers are for hit inputs; marked IN. The channels are arranged sequentially from channel 0 at the top to channel 15 and channel 16 to channel 31. The bottom pins (33,34) on both headers are grounded through 100 ohm resistors. The hit inputs are dECL, polarity is such that a positive going edge on the left hand (odd numbered) pin is interpreted as the leading edge.

**ECLbus output**

The bottom header is the ECLbus output port; marked ECL OUT. This header is used for the FERA compatible readout.

**REAR PANEL**

Located on the back of the unit is a twenty pin header which is the trigger output for the unit. This connector is inverted so pin one is at the bottom. The pins are grouped in pairs, with the bottom pair being the first (pins 1 and 2).

Pair	Function
1 (1,2)	Trigger output 1, ch 0-3
2 (3,4)	Trigger output 2, ch 4-7
3 (5,6)	Trigger output 3, ch 8-11
4 (7,8)	Trigger output 4, ch 12-15
5 (9,10)	Trigger output 5, ch 16-19
6 (11,12)	Trigger output 6, ch 20-23
7 (13,14)	Trigger output 7, ch 24-27
8 (15,16)	Trigger output 8, ch 28-31
9 (pins 17,18)	Output disable (enabled when open)
10 (pins 19,20)	External trigger clock input

**STANDARD CAMAC  
FUNCTION CODES**

<b>F0, A0</b>	Read FIFO data until end of event, Q=1 for valid data, Q=0 at end
<b>F0, A1</b>	Read FIFO data always, (common start only)
<b>F0, A2</b>	Examine FIFO output, do not advance FIFO (common start only)
<b>F1, A0</b>	Read Control register 0
<b>F1, A1</b>	Read Control register 1
<b>F1, A2</b>	Read Control register 2
<b>F1, A3</b>	Read Control register 3
<b>F1, A4</b>	Read Control register 4 (common start only)
<b>F1, A5</b>	Read Control register 5 (common start only)
<b>F1, A6</b>	Read CAMAC Test Register (common start only)
<b>F8, A0</b>	Test LAM
<b>F9, A0</b>	Clear all data and LAM. This does NOT affect the control registers
<b>F10, A0</b>	Clear LAM
<b>F16, A0</b>	Write 16 bit data to FIFO (common start only)
<b>F16, A1</b>	Write FIFO tag bit (common start only)
<b>F17, A0</b>	Write Control register 0
<b>F17, A1</b>	Write Control register 1
<b>F17, A2</b>	Write Control register 2

---

<b>F17, A3</b>	Write Control register 3
<b>F17, A4</b>	Write Control register 4 (common start only)
<b>F17, A5</b>	Write Control register 5 (common start only)
<b>F24, A0</b>	Disable LAM
<b>F24, A1</b>	Disable Acquisition mode
<b>F25, A0</b>	Initiate test cycle (common start only)
<b>F26, A0</b>	Enable LAM
<b>F26, A1</b>	Enable Acquisition mode
<b>F27, A0</b>	Test buffering in progress (BIP), Q=1 while BIP
<b>F27, A1</b>	Test busy, Q=1 while busy
<b>F27, A2</b>	Test event ready, Q=1 if event ready for readout
<b>F27, A3</b>	Test FIFO tag bit, Q=1 if tag bit set for word to be read next
<b>F30</b>	Begin the reprogramming sequence

For completeness, we describe the following commands that are available only during the programming mode of the Model 3377's internal Xilinx logic chip. These enable the mode to be set by selecting a firmware program from the 4 that are installed in the EPROM, or loading a different program from CAMAC. For these commands, the A lines are not decoded, they are simply ignored.

<b>F9</b>	Clear data buffers, enable Xilinx program
<b>F12</b>	Test if Xilinx ready for data (Q=1 when ready)
<b>F13</b>	Test Xilinx programming done (Q=1 when done)
<b>F14</b>	Test Xilinx INIT signal
<b>F16</b>	Write 8 bits to Xilinx
<b>F21</b>	Select EPROM mode 1
<b>F22</b>	Select EPROM mode 2
<b>F23</b>	Select EPROM mode 3
<b>F25</b>	Begin Xilinx programming sequence
<b>F28</b>	Select CAMAC programming mode
<b>F30</b>	Enable Xilinx programming mode (this resets the Xilinx, and selects EPROM mode 0)

# OPERATING INSTRUCTIONS

The 3377 has four separate operating modes. The mode is determined by the Xilinx program loaded from the eprom, see below for changing operating mode. The times are measured with respect to a common hit, which can occur before or after the individual time signal to be measured (Common Stop or Common Start mode). The other mode dependent feature is the data format, which can be either single or double word. A summary of the modes is listed below.

Mode	Operation	Data Format
0	Common Stop	Single Word (Default Mode)
1	Common Start	Single Word
2	Common Stop	Double Word
3	Common Start	Double Word

Since the features and control registers of the modes are quite different in some cases, the control registers, data word formats, and operation of the four different modes are discussed separately in the "Operating Modes" section.

## PROGRAMMING THE UNIT FOR A DIFFERENT MODE OF OPERATION

When initially powered on, the module configures itself for Common Stop, Single Word mode. The module is ready for the first command approximately 200 milliseconds after power on. The first command received by the module must be F9 for correct operation.

To change to any other mode the following sequence of CAMAC operations to the module is required:

1. F30, any subaddress. This selects programming mode and resets the Xilinx gate array. The default program load is the Common Stop mode, Single Word data format.
2. To select a program mode other than the default, perform an F21, F22, or F23 CAMAC operation. To reprogram the Common Stop Single Word mode, simply skip this step.

F21, any subaddress. This selects the common start, single word program load.

F22, any subaddress. This selects the common stop, double word program load.

F23, any subaddress. This selects the common start, double word program load.

3. F25, any subaddress. This begins the programming of the Xilinx chip, using the selected program load (or the default load). This will take less than 200 milliseconds to complete.

- 
4. F13, any subaddress. Test the done flag, return Q=1 when programming is complete. The host computer should loop on this command until Q is equal to 1.
  5. F9, any subaddress. This is REQUIRED after reprogramming. This resets the on board PAL (programmed array logic device) which allows the Xilinx to be programmed, causing all function codes to be ignored by the PAL, except for F30, which starts the reprogramming sequence. The F9 command also MUST be the FIRST command received by the module after power up, to ensure that the PAL has been disabled.

After loading the Xilinx gate array, and performing the F9 command, the Xilinx gate array takes control of the module. The new CAMAC function codes which have been programmed into the gate array logic become operational.

## OPERATING MODES

**IMPORTANT NOTE: The control registers, header contents, data word format, and trigger outputs are dependent on the mode setting.**



**Mode 0: Common Stop,  
Single Word Mode**

**Control Registers**

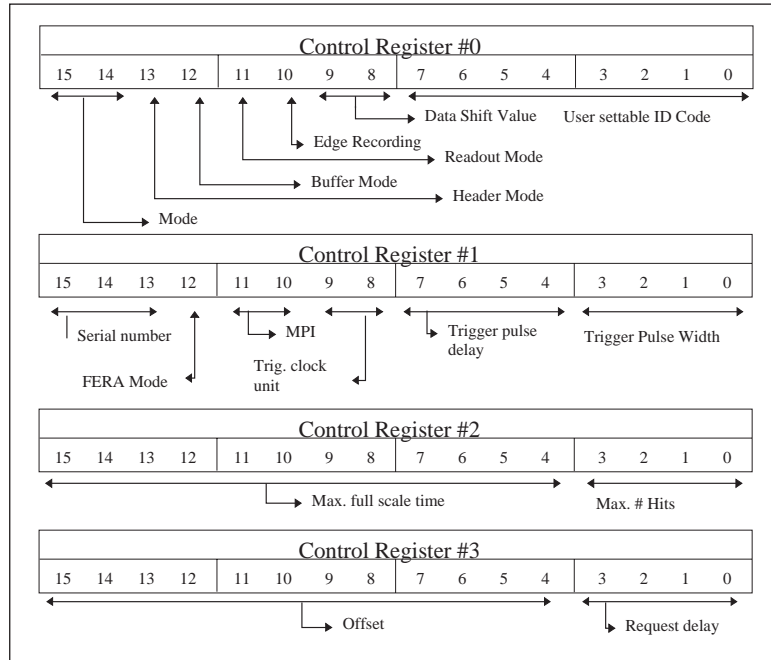

Mode 0 Control Registers

**control register 0 (subaddress 0)**

bits 0-7 user definable module ID code. This appears in the header data word. Default is 0.

bits 8-9 data shift value. This determines the TDC resolution.  
 0 = 0.5 nsec (default)  
 1 = 1.0 nsec  
 2 = 2.0 nsec  
 3 = 4.0 nsec

bit 10 Selects LEADING edge recording, or BOTH edges.  
 1 = Both edges are recorded  
 0 = Leading edge ONLY is recorded (default)

bit 11 Selects readout mode.  
 1 = ECL PORT (FERA mode)  
 0 = CAMAC readout (default)

bit 12 Selects Buffer mode  
 1 = Multi-event buffer mode  
 0 = Single buffer mode. In this mode the FERA readout is compatible with the 4300B FERA ADC. The request delay (see register 3) must be set appropriately. (default)

bit 13 Selects Header mode  
 0 = always have header (default)  
 1 = skip header if no data words

---

bit 14, 15      Read only, indicates the program load in use. Common Stop Single Word mode is 0

**control register 1 (subaddress 1)**

bits 0-3      Selects the trigger output pulse width, in clock units, 0 to 15. Default is 0.

bits 4-7      Selects the trigger pulse delay, in clock units. The maximum delay is 15 clock units. Default is 0.

bits 8-9      Selects the trigger clock unit.  
                0 = 25 nsec (default)  
                1 = 50 nsec  
                2 = 100 nsec  
                3 = selects external trigger clock

bit 10-11     Selects the Measure Pause Interval (MPI).  
                0 = no MPI (default)  
                1 = 800 nsec MPI  
                2 = 1600 nsec MPI  
                3 = 3200 nsec MPI

bit 12         Selects FAST FERA mode  
                1 = fast  
                0 = normal (default)

bit 13 - 15    Event serial number. This 3 bit number is in the header data word. It is incremented after each event. It can be written and read to allow synchronizing several modules. It is cleared by CAMAC command F9. Default is 0.

**control register 2 (subaddress 2)**

bits 0-3      The maximum number of hits allowed per TDC channel, from 1 to 16. A value of zero selects 16 hits. Default is 15.

bits 4-15     The maximum full scale time allowed for the TDC data, in units of 8 nsec, from 0 to 32767.5 nsec. Bit 4 has a value of 8 nsec. This value MUST be set correctly to limit the full scale range to less than the range allowed by the resolution and edge selection specified in register 0. Default is full scale 32767.5 nsec

**control register 3 (subaddress 3)**

bits 0-3      The request delay setting. This is used only in 4300B FERA ADC compatible mode. The range is from 0 to 30 microseconds, in 2 microsecond steps. In this mode the BUSY output becomes the FERA REQUEST output. Default is 0.

---

bits 4-15      The Offset to be subtracted from the data before shifting and readout, in units of 8 nsec. Bit 4 has a value of 8 nsec. This value must be set in a manner consistent with the setting of the maximum time range in register 2. Default is 0.

**A simple example of Common STOP register setup:**

0 = 10FFH      buffered mode, CAMAC readout, leading edge only, 0.5 nsec resolution, header always, module ID is 255

1 = 00FFH      event numbers starts at zero, no MPI, 25 nsec trigger clock, maximum trigger width and delay

2 = 03F0H      full scale is 511 nsec, 16 hits allowed

3 = 0000H      zero offset, and no request delay (not used in buffered mode)

**Maximum Time Range**

The maximum time range is implemented inside the MTD133 monolithic integrated circuit. The range is from 15 counts (7.5 nsec) to 65535 counts (32767.5 nsec). Any data which is GREATER THAN the maximum time range is discarded inside the MTD133 and exacts no readout time penalty. Any data which is EQUAL TO or LESS THAN the maximum time range can be readout.

The maximum time range is set in register 2. Only the upper 12 bits of the 16 bit word are used for the maximum time range. These 12 bits are compared to the upper 12 bits of the data words inside the MTD133. The lower 4 bits are ignored by the hardware inside the MTD133. The maximum data value which can be readout is equal to the maximum time range value + 15 counts, or a multiple of 8 nsec + 7.5 nsec. A value of zero (for the upper 12 bits) allows readout of all data words of 15 counts (7.5 nsec) or less.

**Offset**

The Offset register is implemented on the 3377 board, in the programmable gate array chip. Only the upper 12 bits of this 16 bit word can be set. The lower 4 bits are effectively set to zero. The offset is subtracted from the data read from the MTD133, before the shift is applied. If the data is GREATER THAN or EQUAL to the offset, the result of the subtraction is then shifted (to choose the resolution) and becomes the data to be stored in the FIFO buffer. If the data is LESS THAN the offset, the data is discarded and no data word is stored.

It is possible to implement a time window, using the maximum time range as the upper end and the offset value as the lower end. The upper end is the maximum time range setting + 7.5 nsec. The lower end is the offset value. These two values must be set properly for the resolution and edge mode selected, or the data will be ambiguous. The offset must be less than the maximum time range, and greater than or equal to the

[(maximum time range setting + 15) - difference], where difference is from the table below.

Resolution	Edge Mode	Difference
0.5 nsec	leading edge only	1023
	both edges	511
1.0 nsec	leading edge only	2047
	both edges	1023
2.0 nsec	leading edge only	4095
	both edges	2047
4.0 nsec	leading	8191
	both edges	4095

For 2 nsec resolution and both edge mode, the difference is 2047. For an offset of 512 nsec (a multiple of 8 nsec), the maximum time range value should be 1528 nsec (also a multiple of 8 nsec). There are 512 possible data values, from 0 to 1022 nsec. A raw data value of 512 through 513.5 nsec will be readout as zero, the raw data value of 1534 through 1535.5 nsec will be read out as 1022 nsec.

**NOTE:** Any data which occurs between the lower bound of the window and the common STOP will still be recorded, and will occupy storage space in the MTD133 chip. If a time window is used, it is recommended to set the maximum number of hits to 16, and that the offset value be small.

## Dead Time

The 3377 is a pipelined TDC, and the pipeline is stopped during the transfer of the hit data from the chips to the FIFO event buffer on the board. The time to buffer the data is typically  $1.8 \mu\text{s} + 100 \text{ nsec}$  per hit. During this time the front panel BUSY output is asserted and the module responds with Q=1 to an F27, A1 command. Any inputs received at the front panel will be ignored during this period. Only when buffering of the data is complete and the BUSY is turned off is the module ready to receive data at the front panel signal inputs.

The trigger system must wait for the pipeline to refill before sending a new common stop signal. This refill time should be equal to the maximum time range selected in register 2. It is the responsibility of the trigger system to provide this delay. If a common stop is received before the pipeline has completely refilled (before the maximum time has passed), then valid hits that occurred within the maximum time range, but during the dead time, will not be recorded. If the 3377 is not set to buffer the data then busy will remain on until the data is read out of the unit.

## Front Panel Clear Input

This input is used to clear an event in progress. The CLEAR is effective ONLY between the COMMON STOP and the end of MPI "Measured Pulse Interval (MPI)". If MPI is set to 0, the CLEAR is ignored. To be reliable, the CLEAR must arrive at least 100 nsec AFTER the leading edge of the COMMON STOP, and at least 100 nsec BEFORE the end of MPI (COMMON STOP time plus the MPI setting). The CLEAR signal is synchronized internally with the 100 nsec system clock, and its behavior exhibits 100 nsec of jitter due to the random phase of this clock with respect to the external input signals.

## Mode 1: Common Start, Single Word

### Control Register

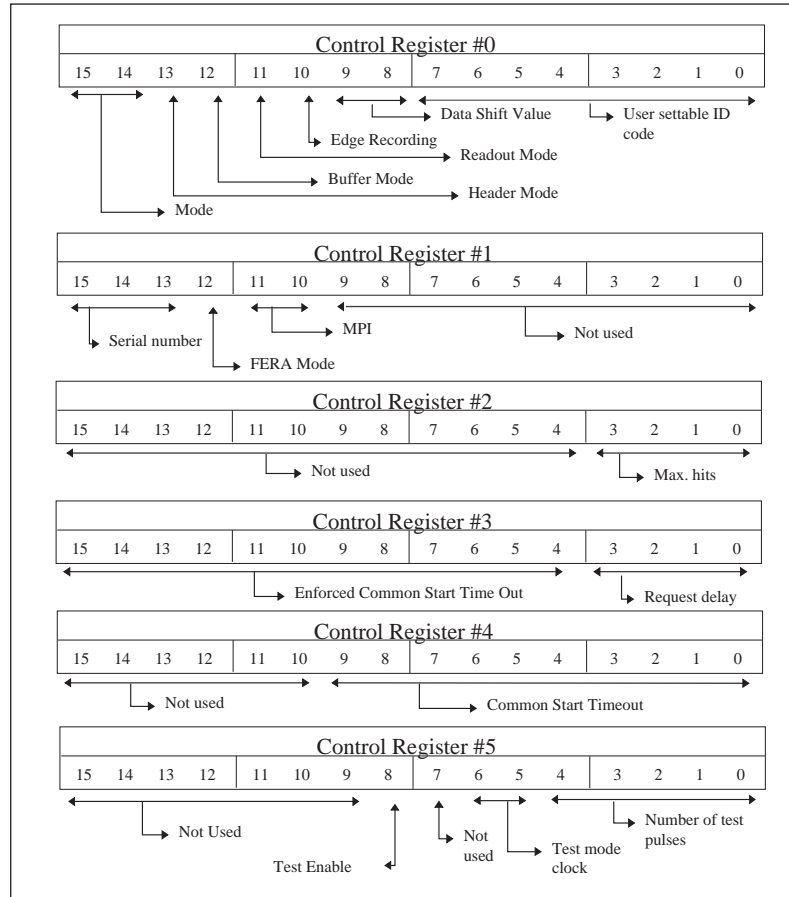

Mode 1 Control Registers

#### control register 0 (subaddress 0)

- bits 0-7 user definable module ID code. This appears in the header data word.
- bits 8-9 data shift value. This determines the TDC resolution.
  - 0 = 0.5 nsec
  - 1 = 1.0 nsec
  - 2 = 2.0 nsec
  - 3 = 4.0 nsec
- bit 10 Selects LEADING edge recording, or BOTH edges.
  - 1 = Both edges are recorded
  - 0 = Leading edge ONLY is recorded
- bit 11 Selects readout mode.
  - 1 = ECL PORT (FERA mode)
  - 0 = CAMAC readout

---

bit 12        Selects Buffer mode  
                 1 = Multi-event buffer mode  
                 0 = Single buffer mode. In this mode the FERA  
                 readout is compatible with the 4300B FERAADC.  
                 The request delay (see register 3) must be set  
                 appropriately.

bit 13        Selects Header mode  
                 0 = always have header (default)  
                 1 = skip header if no data words

bit 14, 15    Read only, indicates the program load in use. Common  
                 Start mode is 1

#### **control register 1 (subaddress 1)**

bits 0-9       not used, always read 0.

bit 10-11     Selects the Measure Pause Interval (MPI).  
                 0 = no MPI  
                 1 = 800 nsec MPI  
                 2 = 1600 nsec MPI  
                 3 = 3200 nsec

bit 12        MPI Selects FAST FERA mode,  
                 1 = fast  
                 0 = normal

bit 13 - 15    Event serial number. This 3 bit number is in the header  
                 data word. It is incremented after each event. It can be  
                 written and read to allow synchronizing several modules.  
                 It is cleared by CAMAC command F9.

#### **control register 2 (subaddress 2)**

bits 0-3       The maximum number of hits allowed per TDC 16 hits.

bits 4-15     Not used, always read 1

#### **control register 3 (subaddress 3)**

bits 0-3       The request delay setting. This is used only 4300B FERA  
                 ADC compatible mode. The range is from 0 to  
                 30 microseconds, in 2 microsecond steps. In this mode  
                 the BUSY becomes the FERA request output

bits 4-15     The maximum time range for the data, tested before  
                 shifting and readout, in units of 8 ns. Bit 4 has a value of  
                 8 ns. This enforces a precise common start time out

#### **control register 4 (subaddress 4)**

bits 0-9       The Common start time out value in units of 50 nsec, up  
                 to 32 microseconds. The minimum delay is about  
                 25 nsec, for a setting of 0. The actual value jitters  
                 50 nsec due to the synchronization with the internal  
                 50 nsec clock. This MUST be set to a value LESS THAN  
                 full scale (32,767.5 microseconds).

---

bits 10-15 Not used, always reads 0

**control register 5 (subaddress 5)**

bits 0-4 The number of pulses generated in test mode. 0-31 pulses, each 1/2 clock period long.

bits 5-6 The test mode clock.  
0 = 100 nsec  
1 = 200 nsec  
2 = 400 nsec  
3 = 800 nsec

bit 7 Not used, always reads 0

bit 8 Test enable. This must be 1 for test mode.

bits 9-15 Not used, always reads 0.

**A simple example of Common START register setup**

0 = 10FFH buffered mode, CAMAC readout, leading edge only, 0.5 nsec resolution, header always, module ID is 255

1 = 0000H event numbers starts at zero, no MPI

2 = 0000H 16 hits allowed

3 = 03F0H time out enforced at 511 nsec, no request delay (not used in buffered mode)

4 = 000BH time out at 550 nsec, slightly longer than the enforced time out delay

5 = 0000H test mode NOT selected

**Common Start Time Out**

A precise common start time out is enforced in steps of 8 nsec by the value in control register 3, bits 4-15. The raw data value is compared to this value. Any data value GREATER THAN or EQUAL TO the timeout value will be discarded. Only data LESS THAN the timeout will be read out. This value MUST be consistent with the resolution and edge mode chosen, or the data will be ambiguous. The Common Start Timeout value must be less than that given in the table below.

Resolution	Edge Mode	Time Out Value
0.5 nsec	leading edge only	1024
	both edges	512
1.0 nsec	leading edge only	2048
	both edges	1024
2.0 nsec	leading edge only	4096
	both edges	2048
4.0 nsec	leading edge only	8192
	both edges	4096

---

The common start time out value from register 4 controls the end of acquisition in steps of 50 nsec, with a 50 nsec jitter due to clock synchronization. This value should be set to result in a minimum time out slightly longer than the value specified in register 3. If the external common stop time out is used, there is no synchronization jitter, and the coincidence resolution can be set precisely.

For example, with 2 nsec resolution and leading edge mode, the maximum time can be as large as 2046 nsec. The time out should be set to 41 (2050 nsec), and the offset value to 2048. This allows use of the full available range.

**NOTE:** Any data which occurs after the enforced Common Start timeout time, but before the actual end of acquisition (the common start time out) will still be recorded. This data will occupy storage space in the MTD133 chip. It is recommended to set the maximum number of hits to a value slightly higher than the number expected.

### **Dead Time**

After the common start time out the 3377 buffers the data. Buffering takes typically  $1.8 \mu\text{s} + 100 \text{ nsec}$  per hit. During this time the front panel BUSY output is asserted and the module responds with Q=1 to an F27, A1 command. Any inputs received at the front panel will be ignored during this period. Only when buffering of the data is complete and the BUSY is turned off is the module ready to receive data at the front panel signal inputs. The module is now ready for a new event, beginning with the common hit. If the 3377 is not set to buffer (see section "Buffered Mode") then busy will remain on until the data is read out of the unit.

### **Front Panel Clear**

This input is used to clear an event in progress. The CLEAR signal is synchronized internally with the 100 nsec system clock, and its behavior exhibits 100 nsec of jitter due to the random phase of this clock with respect to the external input signals.

The CLEAR is effective from COMMON START to the end of MPI. If MPI is set to 0, then CLEAR is effective from COMMON START to the COMMON START TIME OUT. Note that the COMMON START TIME OUT period is effectively an 'MPI'. Note that CLEAR is ALWAYS permitted during the COMMON START TIME OUT period. To be reliable, the CLEAR must arrive at least 100 nsec AFTER the leading edge of the COMMON START, and at least 100 nsec BEFORE the COMMON START TIME OUT or the end of MPI (COMMON START TIME OUT plus the MPI setting).



## Mode 2: Common Stop, double word

### Control Registers

There are only 4 control registers

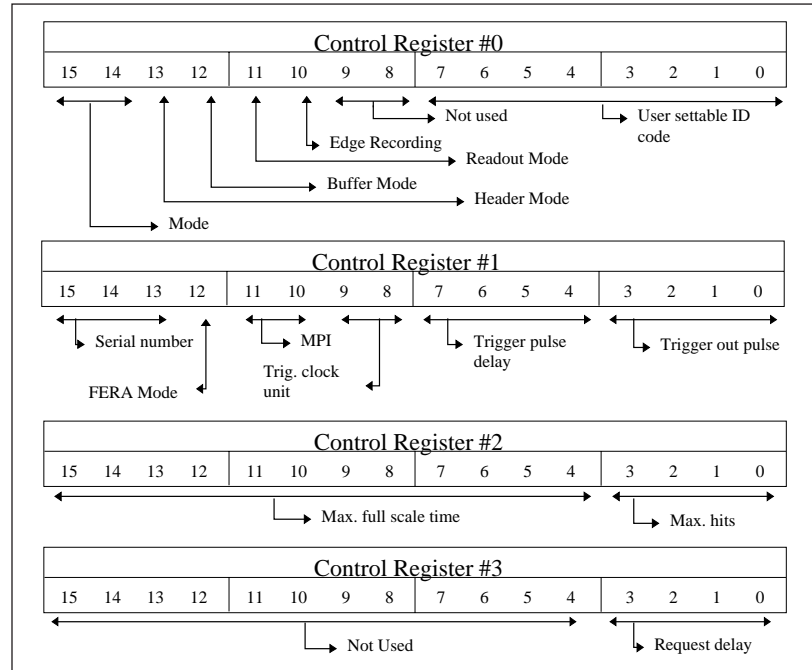

Mode 2 Control Registers

### control register 0 (subaddress 0)

- bits 0-7 user definable module ID code. This appears in the header data word. The default is 0.
- bits 8-9 Not used, always read 0
- bit 10 Selects LEADING edge recording, or BOTH edges.  
1 = Both edges are recorded  
0 = Leading edge ONLY is recorded (default)
- bit 11 Selects readout mode.  
1 = ECL PORT (FERA mode)  
0 = CAMAC readout (default)
- bit 12 Selects Buffer mode  
1 = Multi-event buffer mode  
0 = Single buffer mode. In this mode the FERA readout is compatible with the 4300B FERAADC. The request delay (see register 3) must be set appropriately. (default)
- bit 13 Selects Header mode  
0 = always have header (default)  
1 = skip header if no data words

---

bit 14, 15      Read only, indicates the program load in use. Common Stop Double Word mode is 2

**control register 1 (subaddress 1)**

bits 0-3      Selects the trigger output pulse width, in clock units, 0 to 15. Default is 0.

bits 4-7      Selects the trigger pulse delay, in clock units. The maximum delay is 15 clock units. Default is 0.

bits 8-9      Selects the trigger clock unit.  
                  0 = 25 nsec (default)  
                  1 = 50 nsec  
                  2 = 100 nsec  
                  3 = selects external trigger clock

bit 10-11     Selects the Measure Pause Interval (MPI).  
                  0 = no MPI (default)  
                  1 = 800 nsec MPI  
                  2 = 1600 nsec MPI  
                  3 = 3200 nsec MPI

bit 12         Selects FAST FERA mode; 1=fast 0=normal (default)

bit 13 - 15    Event serial number. This 3 bit number is in the header data word. It is incremented after each event. It can be written and read to allow synchronizing several modules. It is cleared by CAMAC command F9. Default is 0.

**control register 2 (subaddress 2)**

bits 0-3      The maximum number of hits allowed per TDC channel, from 1 to 16. A value of zero selects 16 hits. Default is 15.

bits 4-15     The maximum full scale time allowed for the TDC data, in units of 8 nsec, from 0 to 32767.5 nsec. Bit 4 has a value of 8 nsec.

**control register 3 (subaddress 3)**

bits 0-3      The request delay setting. This is used only in 4300B FERA ADC compatible mode. The range is from 0 to 30 microseconds, in 2 microsecond steps. In this mode the BUSY output becomes the FERA REQUEST output. Default is 0.

bits 4-15     Not used, always read 0.

**A simple example of Common STOP register setup**

0 = 10FFH     buffered mode, CAMAC readout, leading edge only, header always, module ID is 255

- 
- |           |  |
|-----------|--|
| 1 = 00FFH | event numbers starts at zero, no MPI, 25 nsec trigger clock, maximum trigger width and delay |
| 2 = 4E20H | full scale is 10 $\mu$ sec, 16 hits allowed  |
| 3 = 0000H | no request delay (not used in buffered mode)   |

### Maximum time range

The maximum time range is implemented inside the MTD133 monolithic integrated circuit. The range is from 15 counts (7.5 nsec) to 65535 counts (32767.5 nsec). Any data which is GREATER THAN the maximum time range is discarded inside the MTD133 and exacts no readout time penalty. Any data which is EQUAL TO or LESS THAN the maximum time range can be readout.

The maximum time range is set in register 2. Only the upper 12 bits of the 16 bit word are used for the maximum time range. These 12 bits are compared to the upper 12 bits of the data words inside the MTD133. The lower 4 bits are ignored by the hardware inside the MTD133. The maximum data value which can be readout is equal to the maximum time range value + 15 counts, or a multiple of 8 nsec +7.5 nsec. A value of zero (for the upper 12 bits) allows readout of all data words of 15 counts (7.5 nsec) or less.

### Dead Time

The 3377 is a pipelined TDC, and the pipeline is stopped during the transfer of the hit data from the chips to the FIFO event buffer on the board. The time to buffer the data is typically 1.8  $\mu$ s + 200 nsec per hit. During this time the front panel BUSY output is asserted and the module responds with Q=1 to an F27, A1 command. Any inputs received at the front panel will be ignored during this period. Only when buffering of the data is complete and the BUSY is turned off is the module ready to receive data at the front panel signal inputs.

The trigger system must wait for the pipeline to refill before sending a new common stop signal. This refill time should be equal to the maximum time range selected in register 2. It is the responsibility of the trigger system to provide this delay. If a common stop is received before the pipeline has completely refilled (before the maximum time has passed), then valid hits that occurred within the maximum time range, but during the dead time will not be recorded.

If the 3377 is set to single buffer mode (see section "Unbuffered Mode") then busy will remain on until the data is read out of the unit.

### Front Panel Clear Input

This input is used to clear an event in progress. The CLEAR is effective ONLY between the COMMON STOP and the end of MPI. If MPI is set to 0, the CLEAR is ignored. To be reliable, the CLEAR must arrive at least 100 nsec AFTER the leading edge of the COMMON STOP, and at least 100 nsec BEFORE the end of MPI (COMMON STOP time plus the MPI setting). The CLEAR signal is synchronized internally with the 100 nsec system clock, and its behavior exhibits 100 nsec of jitter due to the random phase of this clock with respect to the external input signals.

## Mode 3: Common Start, Double Word Mode

### Control Registers

CONTROL REGISTERS, COMMON START, DOUBLE WORD MODE  
There are 6 control registers.

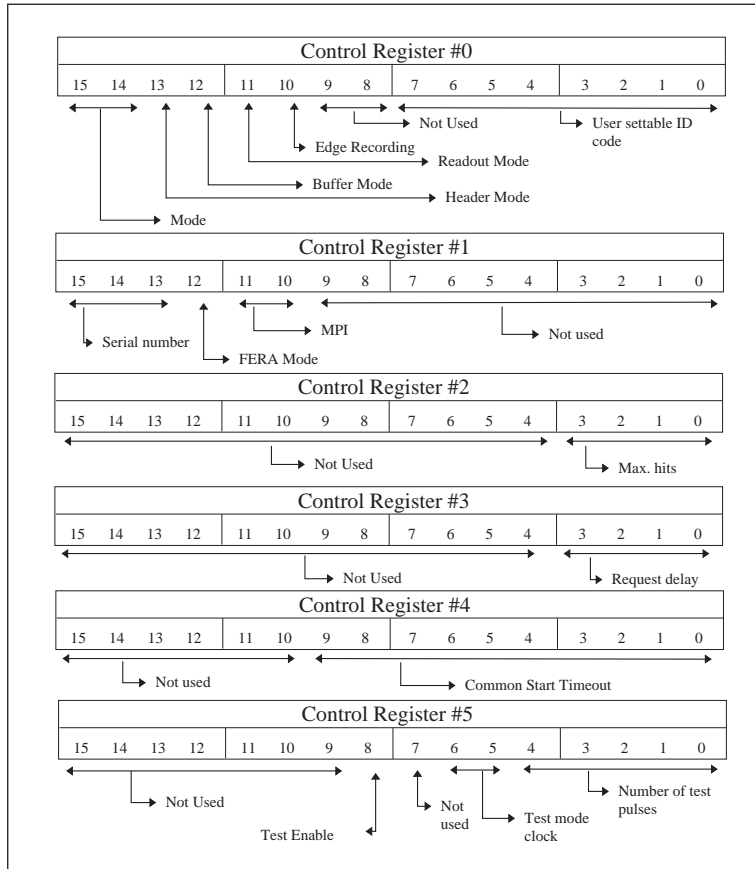

Mode 3 Control Registers

### control register 0 (subaddress 0)

- bits 0-7 user definable module ID code. This appears in the header data word.
- bits 8-9 Not used, always read 0.
- bit 10 Selects LEADING edge recording, or BOTH edges.
  - 1 = Both edges are recorded
  - 0 = Leading edge ONLY is recorded
- bit 11 Selects readout mode.
  - 1 = ECL PORT (FERA mode)
  - 0 = CAMAC readout
- bit 12 Selects Buffer mode
  - 1 = Multi-event buffer mode
  - 0 = Single buffer mode. In this mode the FERA readout is compatible with the 4300B FERA ADC. The request delay (see register 3) must be set appropriately.

- 
- bit 13            Selects Header mode 0 = always have header (default)  
                  1 = skip header if no data words
- bit 14, 15       Read only, indicates the program load in use.  
                  Common Start Double Word mode is 3

**control register 1 (subaddress 1)**

- bits 0-10        Not used, always reads 0.
- bit 10-11        Selects the Measure Pause Interval (MPI).  
                  0 = no MPI  
                  1 = 800 nsec MPI  
                  2 = 1600 nsec MPI  
                  3 = 3200 nsec MPI
- bit 12            Selects FAST FERA mode, 1=fast, 0=normal
- bit 13 - 15      Event serial number. This 3 bit number is in the header  
                  data word. It is incremented after each event. It can be  
                  written and read to allow synchronizing several modules.  
                  It is cleared by CAMAC command F9.

**control register 2 (subaddress 2)**

- bits 0-3         The maximum number of hits allowed per TDC channel,  
                  from 1 to 16. A value of zero selects 16 hits.
- bits 4-15        Not used, always reads 1

**control register 3 (subaddress 3)**

- bits 0-3         The request delay setting. This is used only in 4300B  
                  FERAADC compatible mode. The range is from 0 to  
                  30 microseconds, in 2 microsecond steps.
- bits 4-15        Not used, always read 0.

**control register 4 (subaddress 4)**

- bits 0-9         The Common start time out value in units of 50 nsec, up  
                  to 32 microseconds. The minimum delay is about  
                  25 nsec, for a setting of 0. The actual value jitters 50 nsec  
                  due to the synchronization with the internal 50 nsec clock.  
                  This MUST be set to a value LESS THAN full scale  
                  (32767.5 microseconds).
- bits 10-15       Not used, always reads 0

**control register 5 (subaddress 5)**

- bits 0-4         The number of pulses generated in test mode. 0-31  
                  pulses, each 1/2 clock period long.

---

bits 5-6	The test mode clock 0 = 100 nsec 1 = 200 nsec 2 = 400 nsec 3 = 800 nsec
bit 7	Not used, always reads 0
bit 8	Test enable. This must be 1 for test mode.
bits 9-15	Not used, always reads 0.

#### **A simple example of Common START register setup**

0 = 10FFH	buffered mode, CAMAC readout, leading edge only, header always, module ID is 255
1 = 0000H	event numbers starts at zero, no MPI
2 = 0000H	16 hits allowed
3 = 0000H	no request delay (not used in buffered mode)
4 = 00C8H	time out at 10 microseconds.
5 = 0000H	test mode NOT selected

#### **Common Start Time Out**

The internal common start time out value selected in register 4 controls the end of acquisition in steps of 50 nsec, with a 50 nsec jitter due to clock synchronization. If the external common stop time out is used, there is no synchronization jitter, and the coincidence resolution can be set precisely.

#### **Dead Time**

After the common start time out the 3377 buffers the data. Buffering takes typically 1.8  $\mu$ s +200 nsec per hit. During this time the front panel BUSY output is asserted and the module responds with Q=1 to an F27, A1 command. Any inputs received at the front panel will be ignored during this period. Only when buffering of the data is complete and the BUSY is turned off is the module ready to receive data at the front panel signal inputs. The module is now ready for a new event, beginning with the common hit. If the single buffer mode is selected (see section "Unbuffered Mode") then busy will remain on until the data is read out of the unit.

#### **Front panel Clear**

This input is used to clear an event in progress. The CLEAR signal is synchronized internally with the 100 nsec system clock, and its behavior exhibits 100 nsec of jitter due to the random phase of this clock with respect to the external input signals.

The CLEAR is effective from COMMON START to the end of MPI. If MPI is set to 0, then CLEAR is effective from COMMON START to the COMMON START TIME OUT. Note that the COMMON START TIME OUT period is effectively an 'MPI'. Note that CLEAR is ALWAYS permitted during the COMMON START TIME OUT period. To be reliable, the

---

CLEAR must arrive at least 100 nsec AFTER the leading edge of the COMMON START, and at least 100 nsec BEFORE the COMMON START TIME OUT or the end of MPI (COMMON START TIME OUT plus the MPI setting).

## TRIGGER OUTPUTS

### Trigger Outputs in the Common Stop Modes

The eight prompt OR outputs are stretched (one shots) and delayed (pipeline delay) using digital techniques. The trigger output pulse width and delay can be selected, in increments as small as 25 nsec. The output pulses have a jitter with respect to the input of up to 1 clock period. This is due to the synchronous digital one shot and delay line implemented in the gate array chip. The trigger outputs are latched for the duration of the MPI signal, which begins at the common STOP time. If MPI is set to zero, no latching takes place.

The leading edge of the OR of 4 inputs asynchronously triggers a digital one shot. The width is selected from 1 to 16 clock periods. The clock is selected from 10, 20 and 40 MHz (25 nsec to 100 nsec period), or an external clock which must be less than 40 MHz. The differential ECL external clock input is on the trigger connector, pins 19 and 20. The one shot is retriggerable after one full clock period after the input trigger. If a second trigger arrives during an output pulse, the output pulse is extended.

The pipeline delay is adjustable from 0 to 15 clock periods, using the same clock as the one shot. If zero delay is selected the outputs have the same leading edge time as the OR, but the width displays the jitter due to the clock. If a non zero delay is selected, both the leading and trailing edges are synchronized with the clock, not with the input.

The trigger output data path includes a transparent latch. These latches are transparent during normal acquisition and are latched by the MPI (measure pause interval) which has the leading edge time of the common STOP input. The outputs remain latched until the end of MPI. If the MPI is set to 0 (no MPI) then the latches remain transparent

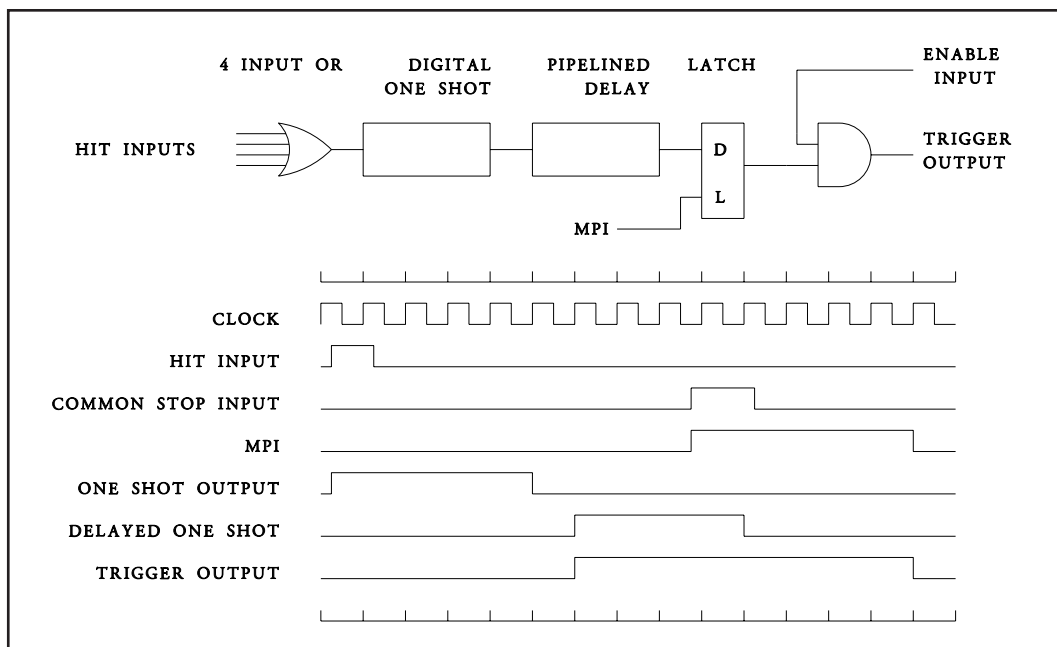



This system enables the experimenter to latch the state of all OR outputs as they existed during the actual event time, even if the common STOP arrives somewhat later than the end of the event time. The width should be set to the desired coincidence resolution (the drift time of the chamber). If the trigger outputs of several 3377 modules are to be combined in a trigger system, an appropriate external clock should be supplied to synchronize the trigger outputs. Otherwise the trigger coincidence resolution must be increased to cover the random phase of the clocks in each 3377 module.

**Trigger Outputs in the Common Start Modes**

The eight prompt OR outputs are used as the clock input to flip flops which are enabled by the common START signal, and disabled by the end of acquisition (the common start time out). Any signal inputs during this interval set the flip flop and are latched. Signals which arrive before the common START or after the time out, are ignored. The latches are not reset until the end of readout (when the system returns to acquisition mode). A fast clear during the MPI will also clear the latches. If the external common stop time out is used, there is no synchronization jitter, and the coincidence resolution can be set precisely.

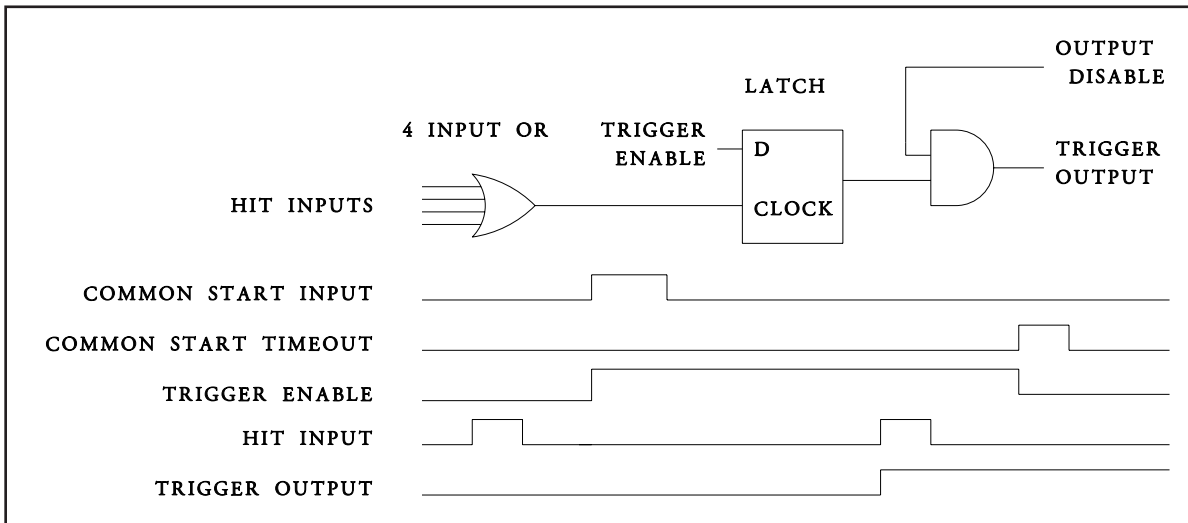

---

## READOUT MODES AND DATA FORMATS

### CAMAC

#### Buffered Mode

This is the recommended CAMAC mode. With single word output format, the multievent buffer will hold up to 8 full size events (512 data words + header for each event). In double word format the buffer will hold 4 events (1024 data words + header for each event), or up to 31 smaller events. The limit is 4095 words in the FIFO. The FIFO can actually hold up to 8192 words, however no more events will be accepted after the half full flag is turned on.

CAMAC readout is on an event by event basis, using F0, A0. A Q=1 is returned if the data is valid. After the last data word for that event has been read, the next F0, A0 always returns Q = 0. If another event is waiting to be read the next F0, A0 will return the header word for the next event with Q = 1, otherwise the module will continue to return Q=0.

#### Unbuffered mode

The only difference is the behavior of the BUSY signal on the front panel (and tested with F27, A1). Normally, the BUSY becomes true when the common stop or common start time out is received, and remains on only until the data is stored in the FIFO. In unbuffered mode, the BUSY is delayed by the request delay setting (register 3), and remains true until the data has been read from the module (the FIFO is empty again).

### ECLPORT (FERA) mode

#### Buffered mode

The behavior of the data and the BUSY signal is the same as for CAMAC readout. This mode is NOT COMPATIBLE with 4300B FERA ADC modules. The ECLbus must consist only of 3377 (or 3377 compatible modules). Standard FERA modules may not be intermixed.

#### Unbuffered mode

This mode IS COMPATIBLE with the original FERA modules. The 4300B ADC modules must be installed first in the ECLbus (closer to the 4301 FERA driver). The BUSY signal now becomes the REQ line in the FERA control bus. The request delay should be set to a value such that it comes on after the 4300B REQ signal, but before the 4300B can finish reading out. This mode should be used only for 4300B compatibility. If compatibility is not required, the buffered mode should be used.

### FERA COMPATIBILITY

Beginning with ECO #1101, the Model 3377 time digitizer has improved compatibility with the Model 4300B FERA ADC. This change involves firmware only, and is compatible with all production circuit boards (rev A&B).

With this change, the REN signal can be used as flow control for the ECLport output in the same way as the 4300, when the 3377 is in unbuffered mode. In addition, a new mode has been provided which allows the use of WAK for flow control when the 3377 ECLport is operated in the fast mode. The improved compatibility is summarized below.

#### Standard 4300B FERA Behavior

Conversion begins when a gate is received by the 4300B ADC module. After the conversion is finished all modules which have data to be read out assert the REQ line. REQ continues to be asserted until that module

---

has been completely read out. The wire ORed REQ lines are received by the 4301 driver which waits for an adjustable delay (up to 0.5 microsecond to be sure that all 4300Bs have finished conversion), then sends REN to the first 4300B on the ECLbus. The data is then handshaked out to the ECLbus using WST and WAK. After all data has been sent, REQ is removed and PASS becomes a copy of REN.

If the first 4300 has not asserted REQ (there was no data above the sparse scan threshold), then REN is simply copied to PASS. It is critical that REN not be asserted until all 4300Bs have finished conversion, because while REQ is not asserted, REN is simply copied to PASS.

If WST and WAK are used in the standard handshake mode, they control the data flow. However, for high speed pipelined readout, WAK can be jumpered to WST using the WSO and WAI connectors on the 4301 driver, effectively bypassing the handshake. The maximum ECLport rate is achieved this way. In this case REN is used as the flow control. Dropping REN effectively pauses the data flow. This works fine for the 4300B since there is only one data buffer. When REN returns, the data flow resumes.

#### **Modified Model 3377 FERA Behavior**

The 3377 TDC begins conversion after the end of acquisition, after the common stop or the common start time out. The conversion time is not fixed however, it depends on the amount of data and the mode (single or double word). The conversion time can be as short as two microseconds or as long as 103 microseconds. In addition, the 3377 has a multi event buffer, which can hold as many as 31 events. Fortunately, the 3377 can also be operated in an unbuffered mode, which although slightly different than the 4300B FERA ADC, is quite compatible with it.

In the multi buffer mode, REN is used as a token to read out one event from each 3377. As soon as conversion starts, BUSY (REQ) is asserted. BUSY is removed as soon as the event is safely stored in the buffer. If REN arrives before conversion is complete (and no previous event is waiting in the buffer) the module simply waits for an event to become ready. When the event has been completely read out, PASS is asserted and the module waits for REN to become false. Then PASS is set false and the module is ready to read out the next event in the buffer. This ensures that each event is read out completely before any part of the next event is read. This use of REN as an event token is incompatible with the use as a flow control device in the 4300B FERA system. Note that REN can be asserted even before the event, the module simply waits for the event.

#### **4300B Compatible Mode**

The single buffer mode is compatible with 4300Bs on the same ECLbus. In this mode the BUSY signal becomes REQ. REQ can be delayed in 2 microsecond steps from 2 to 30 microseconds after the end of acquisition (the common stop, or the common start time out). REQ must not come on before any 4300Bs on the ECLbus have finished conversion and decided whether or not to assert REQ. REQ stays on until the data has been read from the module. If REN arrives before conversion is complete, the module waits for the event. During readout REN can be used as flow control. After readout (and until the next conversion begins) REN is simply copied to PASS. This allows REN to be used as flow

---

control for modules later on the ECLbus. Note that 4300Bs and 3377s can be arranged in any order on the ECLbus.

### **Fast FERA Mode**

The 3377 has 2 FERA modes, normal and fast. These are available both in multi event buffered and single buffer modes. In normal FERA mode, flow control is automatic, and uses the WST-WAK handshake. A fast FERA mode can be selected by setting a bit in a control register, which allows readout at 10 Mwords per second by ignoring the handshake. The WST to WAK jumper is not required, so WAK is available for use as flow control. Asserting WAK causes data readout to pause after the current word. Readout will resume when WAK is removed. Note that the use of WAK for flow control is not currently supported by the 4301 FERA driver module (except as part of the WST-WAK handshake).

### **DATA FORMATS**

The 3377 output data is in either single or double word format. These formats are identical for Common Start or Common Stop operation, and for CAMAC or ECLbus readout.

### **Single Word Format**

The output data consists of a header word, followed by up to 512 data words. An event with no data consists of only the header word. If header suppression is selected, an event with no data results in zero words.

#### **HEADER**

bits 0-7	the 8 bit module ID (from register 0)
bits 8-9	the 2 bit resolution value (from register 0)
bit 10	the leading/both edge recording bit (from register 0). 0 = leading only 1 = both
bits 11-13	the event serial number, modulo 8
bit 14	always 0, identifies single word readout
bit 15	always 1, identifies header word

#### **DATA WORD, leading edge only recording**

bits 0-9	10 bit data value
bits 10-14	5 bit channel number
bit 15	always 0, identifies data word

#### **DATA WORD, leading edge AND trailing edge recording**

bits 0-8	9 bit data value
bit 9	Identifies the edge, 0 = leading, 1 = trailing
bits 10-14	5 bit channel number
bit 15	always 0, identifies data word

### **Double Word Format**

The output data consists of a header word, followed by up to 1024 data words. An event with no data consists of only the header word. If header suppression is selected, an event with no data results in zero words.

#### **HEADER**

bits 0-7	the 8 bit module ID (from register 0)
bits 8-9	the 2 bit resolution value, always 0

---

bit 10	the leading/both edge recording bit (from register 0). 0 = leading only, 1 = both
bits 11-13	the event serial number (modulo 8)
bit 14	always 1 (identifies double word readout)
bit 15	always 1, identifies header word

#### **FIRST DATA WORD**

bits 0-7	8 bit data value
bit 8	1, indicates that the data is the most significant byte.
bit 9	Identifies the edge, 0 = leading, 1 = trailing
bits 10-14	5 bit channel number
bit 15	always 0, identifies data word

#### **SECOND DATA WORD**

bits 0-7	8 bit data value
bit 8	0, indicates that the data is the least significant byte.
bit 9	identifies edge, 0 = leading, 1 = trailing
bits 10-14	5 bit channel number

#### **SUPPRESSING THE HEADER**

The Header mode bit, register 0, bit 13, when set to 1, allows suppressing the header word if there is no data in the event. This is effective in all readout modes, single or double word, buffered or unbuffered, CAMAC or FERA. The event is not suppressed, only the header, so the event ordering remains correctly synchronized among multiple 3377 modules. If the channel occupancy is low, the use of this feature can result in a reduction in the size of the data block for each event, and a small decrease in readout time (not the same as the dead time). It is recommended that the last module in a readout group be set to always supply the header (bit 13 set to 0).

---

**EXAMPLE 3377**  
**PROGRAMMING SEQUENCE**

- Step 1:** CAMAC Reprogramming (see Operating Instructions)  
F9, any subaddress (should be executed as first command after powerup)  
F30, any subaddress (selects programming mode, resets Xilinx chip)  
F21, any subaddress (selects common start, single word mode)  
F25, any subaddress (begins reprogramming of Xilinx chip)  
Wait 500 ms for programming to finish (actual time: < 200 ms)  
F13, any subaddress (check programming complete)  
F9, any subaddress (reset PAL)
- Step 2:** Initialize module (for Common Start example)  
F17 A0, data = 0x10FF  
F17 A1, data = 0x0000  
F17 A2, data = 0x0000  
F17 A3, data = 0x03F0  
F17 A4, data = 0x000B  
F17 A5, data = 0x0101  
F1 A0 (read back register 0 to check)  
F1 A1 (read back register 1 to check)  
F1 A2 (read back register 2 to check)  
F1 A3 (read back register 3 to check)  
F1 A4 (read back register 4 to check)  
F1 A5 (read back register 5 to check)  
F26 A0 (Enable LAM)
- Step 3:** Enable Acquisition Mode  
F26 A1
- Step 4:** Execute Test Cycle  
F25 A0
- Step 5:** Test Event Ready to Readout  
F27 A2
- Step 6:** Read back data  
F0 A0 (read data until Q=0)

# THEORY OF OPERATION

The Model 3377 time digitizer consists of 7 major subsystems:

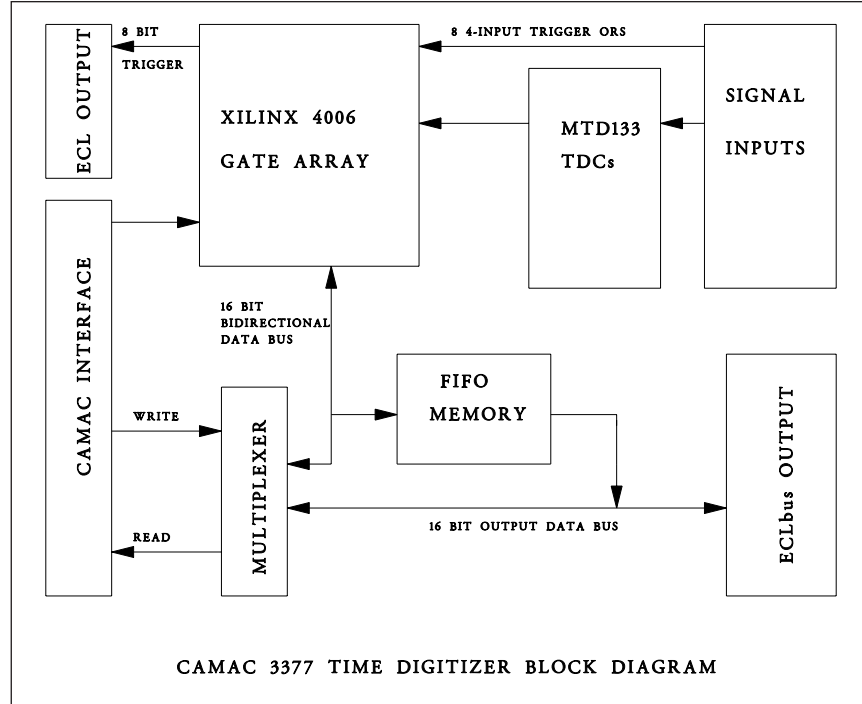

## TIME MEASUREMENTS

Four LeCroy MTD133 custom monolithic integrated circuits perform the actual time measurements. The 250 MHz clock is provided by a crystal oscillator, and a symmetrizing circuit which adjusts the duty factor to 50%. The MTD133 uses a synchronous counter which counts on both clock edges, giving an effective counting rate of 500 MHz. A four stage delay line interpolator divides the counting period into 500 picosecond intervals. A phase locked loop using an external op amp in the feedback circuit adjusts the delay line to be exactly 2 nsec long. When an input occurs, the grey coded counter and interpolator are latched and stored in the LIFO.

Each MTD133 contains 8 input channels, each with 16 words of LIFO storage. Both the depth of the storage, and the maximum time range are programmable. The data is stored in the LIFO in a grey code format. When the data is read out, the grey code is converted to binary, the Common hit time is subtracted, and the time difference is compared to the maximum time. This is done in a 3 stage pipeline to increase the readout speed. The readout is in channel order, and then reverse time order., the most recent hit in a channel is read first. When the channel is empty, or a hit with a time greater than the programmed maximum is encountered, the readout proceeds to the next channel.

## CONTROL AND READOUT

At the beginning of acquisition mode, the programmed values for hit depth and time range are loaded into the MTD133s. At the end of acquisition, when a Common Stop, or a Common Start Time Out is received, the inputs are disabled, and readout begins. Three priming pulses are required to fill the internal pipelines in the MTD133s, then

---

readout proceeds at 100 nsec per hit. In Common Stop Single Word mode, the offset is subtracted, the data is shifted to adjust the resolution, and the correct number of bits are inserted into the output data word. Valid data is stored in the event buffer. This takes place in a three stage pipeline inside the Xilinx chip. While this pipeline is starting up, the header word is written into the event buffer. When all MTD133s have been unloaded a tag word is written into the event buffer to separate events. Similar sequences occur for the three other operating modes.

#### **EVENT BUFFER MEMORY**

The buffer memory is supplied by two 9 by 8192 FIFO chips. Sixteen bits are used for the data, and one bit as a tag to separate events in the FIFO. Writing to the FIFO is done by the MTD readout, or by the CAMAC interface for testing. The half full flag is used to block further events by keeping the BUSY on. When enough data has been read to reduce the FIFO below half full, the BUSY will become false. Readout from the FIFO is either by CAMAC or the ECL port. A separate FIFO, located inside the Xilinx chip records the data status (some or none) for each event, to facilitate header suppression. An event counter, also located inside the Xilinx chip keeps track of the number of complete events stored in the FIFO.

#### **CAMAC INTERFACE**

The CAMAC interface uses a PAL to provide the startup sequence of loading the Xilinx chip with one of 4 programs stored in an EPROM. After programming, the PAL is disabled (except for F30) and all CAMAC decoding is done inside the Xilinx chip. The CAMAC data path is 16 bits bidirectional to the Xilinx chip, and 16 bits read only from the event buffer outputs. A multiplexer is required in the data path to select the Xilinx or event buffer data source.

#### **ECL PORT**

A high speed PAL provides the logic for the WST-WAK handshake, the REN-PASS logic and the event buffer read pulses. Standard TTL-ECL level shifters are used to drive the outputs. The pull down resistors on the outputs are installed in sockets, to allow bussing of the ECL port connectors into a LeCroy 4301 FERA driver or equivalent.

#### **TRIGGER OUTPUTS**

The 32 dECL input signals are OR'ed together in groups of 4 and converted to 8 TTL signals. These are input to the Xilinx chip. The digital one shots, digital delay and latch circuits all reside inside the Xilinx chip. The 8 output signals are converted back to ECL and are available at the rear panel. An external clock input allows the synchronization of the digital one shots and delay for multiple 3377 modules.

#### **SUPPORT CIRCUITS**

Nearly all control logic for the module is located in the Xilinx programmable gate array. Most of the circuitry on the board (except for the MTD133s) consists of data path and support circuits. The versatility of this module is entirely due to the large amount of logic which can be programmed into this gate array chip. This is many times the amount that can be placed on a CAMAC board using ordinary integrated circuits.

The remaining support circuits on the board consists of power supplies, level shifters and input signal conditioning.



## ADDITIONAL INFORMATION

**TESTING THE MODEL 3377** The Model 3377 TDC is designed to be easily tested in situ. The complete CAMAC interface, the MTD133 integrated circuits and the time base can be checked without any cable changes.

The CAMAC data interface is readily tested by writing and reading back arbitrary 16-bit data patterns to control register 1, via the F17•A1 and F1•A1 commands, respectively.

The function code and subaddress lines are tested with a special register, which exists only in the Common Start modes. On every CAMAC instruction in the crate, the F, A, I, C and Z lines are latched at S2. These can be read if the very next instruction is F1, A6, to a 3377 module (which is in Common Start mode).

CAMAC Bit	Read Line
A1	R1
A2	R2
A4	R3
A8	R4
F1	R5
F2	R6
F4	R7
F8	R8
F16	R9
I	R10
Z	R11
C	R12
	bits R13-R15 always read 0

Control register 5 in Common Start mode controls the built in test pattern generator. Bit 8 must be set to enable test mode (this disables the front panel inputs). The number of pulses is selected by bits 0-4, from 0 to 31 pulses. These pulses are applied to all 32 channels. The pulse period is selected with bits 5 and 6, as 100, 200, 400 or 800 nanoseconds. The Common Start time out, number of hits and resolution must be set appropriately. The test event is triggered by an F25, A0 command. This will produce one event in the FIFO buffer, with data as selected above.

The pulse period is derived from the 40 MHz logic clock, which is used for the control logic and the trigger system. This is independent of the 250 MHz clock used for the MTD133 time base. Since these two clocks are independent, these test pulses can be used to approximately verify the time base, and to approximately measure the RMS resolution of the MTD133 time digitizers. For a discussion of the RMS error and how to measure it correctly, please refer to the LeCroy application note, AN-50A.

---

The FIFO data buffer is tested with two special write instructions. An F16, A0 will write arbitrary 16 bit data into the buffer. An F16, A1 will write the end of event tag into the buffer, and increment the event counter. These two instructions allow one to fill the buffer with dummy events. These can be read out over CAMAC, testing the entire data path. If the ECLport is connected, these dummy events can be read out through the model 4301/4302 memory system, testing that data path as well.

## **EXTENDING THE TIME RANGE**

The Model 3377 has several features which make it possible to extend the time range beyond the normal 32 microsecond full scale. The dead time is short, 1.8 microseconds plus 200 nanoseconds per hit (double word mode). The 4000 word multiple event buffer can hold up to 2000 hits (double word) or up to 31 events. The ECL port readout can transfer data at 100 nanoseconds per word. The maximum number of hits per channel is programmable, which allows one to absolutely limit the dead time to read out the TDC chips into the buffer memory. There are at least two basic methods (and many variations) of using these features to extend the full scale time range.

Two 3377 TDCs can be operated alternately, in a ping pong mode, to provide a continuous, deadtimeless, time stamping TDC. A 2366 universal logic module can be programmed to supply a common stop alternately to the two 3377 modules, at 32 microsecond intervals. Identical input signals are provided to both 3377 TDC modules. The maximum number of hits is set to limit the total to less than 150 (300 data words). For example, 4 hits per channel if all 32 channels are used, or 16 hits per channel if 9 or fewer channels are used. The dead time to buffer an event (a common stop) is then less than 32 microseconds (while input data is being recorded by the other module). Each 3377 can store 31 events (or 4000 data words), for a total of nearly 2 milliseconds of recording. Each event consists of the header and up to 150 data hits, allowing simple reconstruction of the absolute time by counting headers. If the ECLport is used to remove the data from the 3377s, the recording time is limited only by the external memory buffer. For example, using a 4302 FERA memory, the system can record 2.4 milliseconds at the full data rate, or up to 0.5 second at a low hit rate.

If the experiment requires recording times of bursts of events which have a minimum time separation of at least a few microseconds between bursts (for example, a period measurement), and therefore can tolerate a small dead time to record each event, a long time range can be provided using only one 3377 and one 2366 universal logic module. The 2366 can be programmed to use the 3377 trigger outputs to create a common stop trigger when an event occurs. The 2366 also provides a 16 bit counter, counting a 100 kHz clock.

There are two ways to record this counter value with each event. The first method creates a bit pattern using 16 TDC inputs. The 16 bit counter word is strobed after each count, to provide a pulse pattern (each '1' bit produces a pulse) which is sent to sixteen of the 3377 inputs. The 3377 maximum time range is set to 11 microseconds. This ensures that at least one counter pattern is recorded along with each

---

event. The 3377 measures the time of the event relative to the 100 kHz clock. The correct absolute time is calculated by using the 100 kHz counter value as a coarse clock. The dead time is 5 microseconds (worst case for 16 bits equal to 1) plus the time for the event data. Sixteen input channels are available for the event data. The data block is 17 words (average) plus the event data. Another method is simply to read out the counter data as part of each event, either by CAMAC or the ECL port. A 31 word FIFO can easily be programmed into the 2366 to match the event FIFO in the 3377.

The 16 bit counter allows 655 milliseconds of recording before rollover. A null event can be provided to record the rollover, allowing an unlimited time range. More than 31 events can be recorded if the ECL port is used to move the data to an external buffer. With the 4302 memory as above, as many as 1000 events may be recorded.

Both of these methods can use one of the 2277/EXP modules, to provide improved double hit resolution and more hits per channel (for fewer channels). When using two 3377s in a ping pong mode, the EXP modules can drive a double termination to provide the identical signals to the TDC modules. The EXP module drives the center of a short cable (the cable has 3 connectors), the two ends connect to the two 3377s. This will only work for short cables, since the differential ECL signal is reduced in amplitude by 40%. Note that the lower connector on the 2277/EXP module is inverted.

The internal clock in the 3377 provides 0.5 nanosecond accuracy for intervals less than the 32 microsecond full scale. The accuracy of the extended time range depends on the clock used in the 2366 universal logic module. For accurate results with the extended time range, the external clock input must be used, not the internal crystal time base. A readily available time standard is based on Loran-C reception, and can provide 0.5 nanosecond accuracy for intervals up to one minute.

## **LABVIEW™ SUPPORT**

You can download a driver for LabView 4.x from our website at <http://www.lecroy.com/lrs/support.htm>.

# INDEX

<b>Symbols</b>		COM	15
4300B	38	PASS	15
8007A	11	REN	15
8025	11	T-O	15
8901A	11	WAK	15
		WST	15
<b>B</b>		Internal Tester	13
BUSY	28, 38	<b>L</b>	
BUSY Output	15, 24, 31, 34	LabView™ Support	47
<b>C</b>		<b>M</b>	
Cables	11	Maintenance Agreements	9
Flat Multiwire	11	Maximum Time Range	23, 31
Single Twisted Pair	11	Measured Pulse Interval (MPI)	15, 24, 28, 31, 34
Twisted-pair Multiwire	11	MTD133	23, 28, 31
CAMAC	11	<b>O</b>	
CAMAC Function Codes	16	Offset	23
Clear	15, 24, 28, 31, 34	Operating Modes	20
Clear Input	24	Mode 0	21
Common Input	15	Mode 1	25
Common Start	13	Mode 2	29
Common Start Time Out	13, 27, 28	Mode 3	32
Common Stop	13	<b>R</b>	
Control and Readout	43	Readout Modes	38
Customer Service	9	<b>T</b>	
<b>D</b>		Testing	45
Data Formats	19, 38	Time Measurements	43
Displays	15	Time Range	46
<b>E</b>		Timeout Input	15
ECLbus	15, 16	Trigger Outputs	22, 36, 37
<b>F</b>		<b>W</b>	
FERA	38	Warranty	9
FERA Compatibility	38		
Front Panel	14		
<b>I</b>			
Inputs and Outputs	15		
BSY	15		
CLR	15		