

CAMAC MODEL 7145 OCTAL LINEAR GATE / MULTIPLEXER

FEATURES

- Eight Independent Fast Analog Switches
- Analog Bandwidth - DC to 250 MHz
- Ideal for Fast Analog Multiplexing
- Fully Bipolar Operation to ± 2.5 Volts
- Gateable with TTL, NIM, ECL signals or via CAMAC

The model 7145 is an eight channel unity gain linear gate and multiplexer packaged in a single width CAMAC module. Each channel has an analog input of 50 ohms, two unity gain 50 ohm outputs, a DC offset control and a gate input that responds to NIM, TTL or ECL inputs. Bipolar analog signals from DC to 250 MHz can be switched ON or OFF in just two nanoseconds in any combination, from external control or via CAMAC control. An additional pair of outputs, SUM/MUX, provides the linear summation of all eight channels. This can be used to perform eight line to one line linear multiplexing or can provide the total charge of all inputs simultaneously gated.

INPUT CHARACTERISTICS

Inputs	:	One LEMO connector per channel, bipolar input accepts positive or negative voltages; impedance 50 ohms; $\pm 2\%$ direct coupled, input reflections less than $\pm 4\%$ for 1 μ Sec risetime.
Protection	:	Protected with clamping diodes; no damage will occur from transients of ± 100 Volts (± 2 amps) for 1 μ Sec or less duration.
Gate Input	:	One LEMO connector per channel, 50 ohm impedance for NIM inputs, 1000 ohms for TTL Inputs, direct coupled; The analog switch is normally closed with no gate signal; With negatively going NIM or positively going TTL signals the analog switch opens. Gate opening and closing times are less than 2 nSec.
ECL Gate	:	A rear panel connector provides individual gating of each channel from differential ECL inputs, 100 ohm impedance; A removable termination is used to facilitate data bus chained architectures.
Common Gate	:	Front panel LEMO connector, gates all channels simultaneously; Accepts NIM or TTL signals (same characteristics as the individual gate inputs.)
Off Isolation	:	Analog Isolation greater than 54 db for 100 MHz inputs.
Gate Feedthrough	:	Less than 1 pC, or less than ± 40 pVolt second glitch.

OUTPUT CHARACTERISTICS

General	:	Two bridged LEMO output connectors per channel; Low impedance voltage source output stage fully protected from continuous shorts to ground without suffering damage.
Output Voltage Swing	:	Bipolar outputs deliver over ± 2.5 Volts across two 50 ohm loads.
DC Offset	:	A front panel 15-turn potentiometer provides ± 500 mVolt adjustment. A front panel test point allows easy monitoring of the DC offset.
SUM/MUX	:	Two bridged LEMO connectors; The output is the linear summation of any or all channels selected. Gain equals 0.5 $\pm 3\%$, bipolar output range to ± 4 Volts into two 50 ohm loads; outputs protected from shorts to ground; DC offset control with monitor has ± 500 mVolt adjustment range. Bandwidth is DC to 200 MHz.

MODEL 7145 (continued)

GENERAL PERFORMANCE

Gain	:	Fixed gain of 1.0 \pm 2% non-inverted.
Stability	:	Better than \pm 100 μ Volt/ $^{\circ}$ C from DC to 1 MHz, and \pm .05%/ $^{\circ}$ C above 1 MHz.
Linearity	:	\pm 0.4%, output to \pm 2 Volts across 50 ohm load.
Bandwidth	:	DC to 250 MHz, 3 db point 1 Volt peak to peak.
Wideband Noise	:	Less than 500 μ Volts RMS, referred to the input, $<$ 30 nV/ \sqrt Hz.
Risetime	:	Typically 1.4 nSec, for a 1 Volt output excursion.
Crosstalk	:	Channel Isolation greater than 54 db, DC to 100 MHz.
Input to Output Delay	:	Typically 4 nSec.
Power Supply Requirements	:	-6 V @ 400 mA -24 V @ 400 mA +6 V @ 400 mA +24 V @ 400 mA
Operating Temperature	:	0 $^{\circ}$ C to 60 $^{\circ}$ C ambient.
Packaging	:	Standard single width CAMAC module in accordance with ESONE Report EUR 4100.

CAMAC COMMANDS

C and Z	:	Responds to CAMAC clear and initialize, clears gate register at S ₂ time.
N·F0·A0	:	Reads contents of gate register (R1-R8).
N·F16·A0	:	Writes Gate register pattern (W1-W8).
Q	:	Response generated if function executes.
X	:	Response generated on valid N,A,F command.

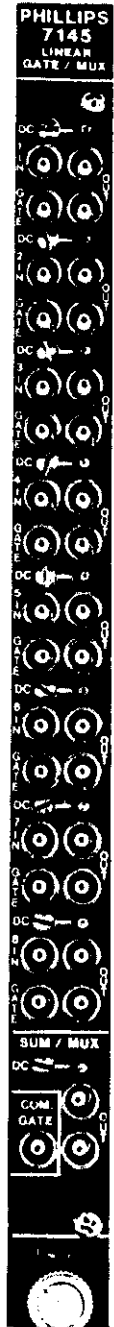

MODEL 7145 GATE CHARACTERISTICS

**100 MHz CW
1 Volt P-P
(200 mV/Div.)**

**Gate Input (NIM)
(500 mV/Div.)**

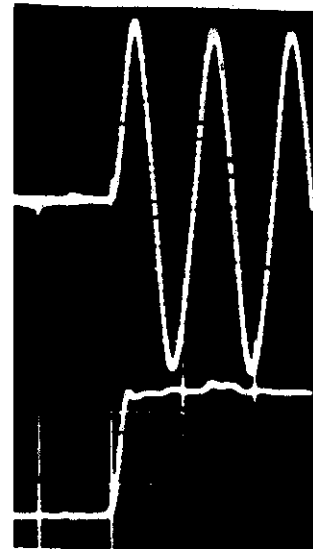
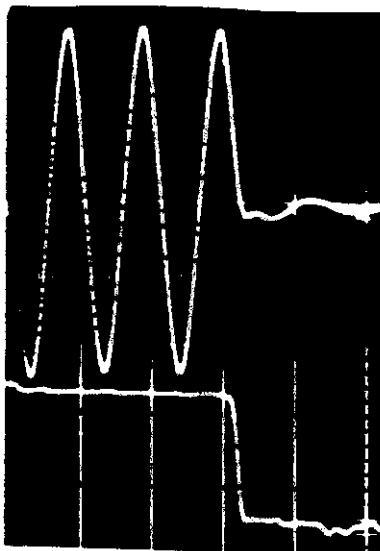

10 nS | iv.

**200 MHz CW
1 Volt P-P
(200 mV/Div.)**

**Gate Input (NIM)
(500 mV/Div.)**

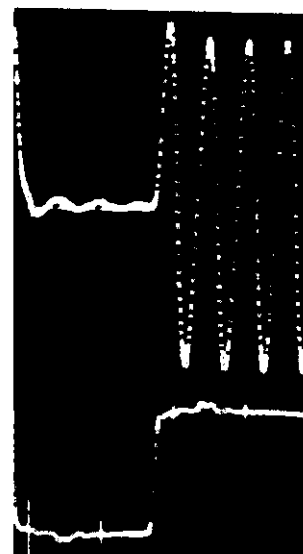
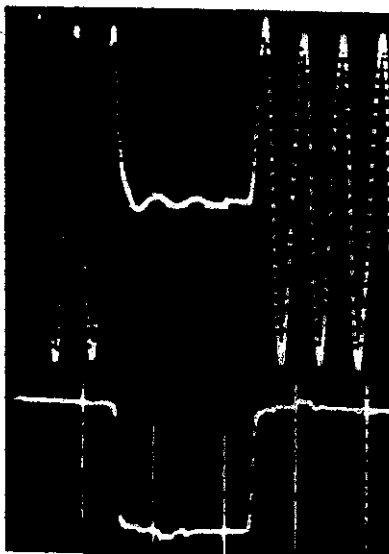

10 nS/ | iv.

**Gate Input
(200 mV/Div.)**

**Gate Feedthrough Transients
(5 mV/Div.)**

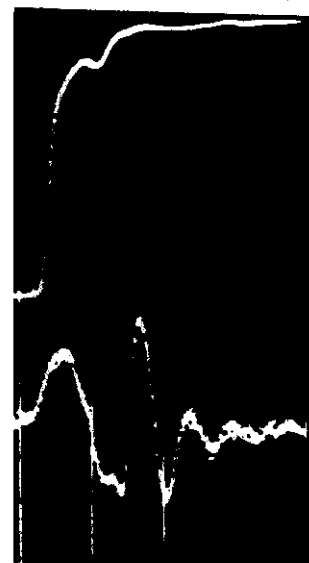
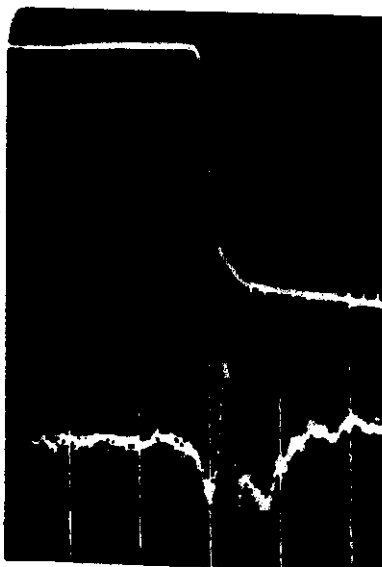

5 nS/D

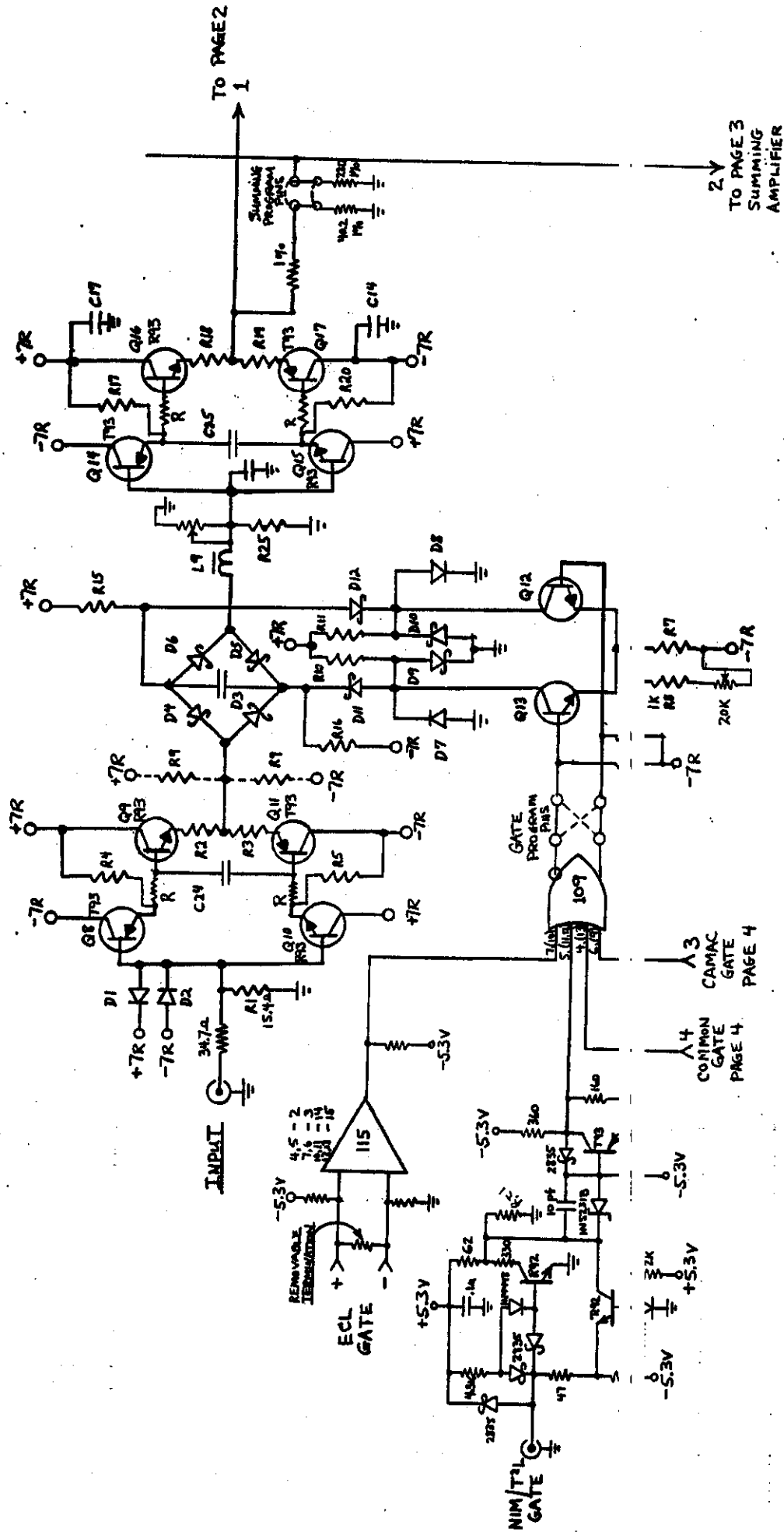

ADDITIONAL COMPENSATION COMPONENTS ARE ADDED WHERE
 REQUIRED TO ENHANCE CIRCUIT PERFORMANCE

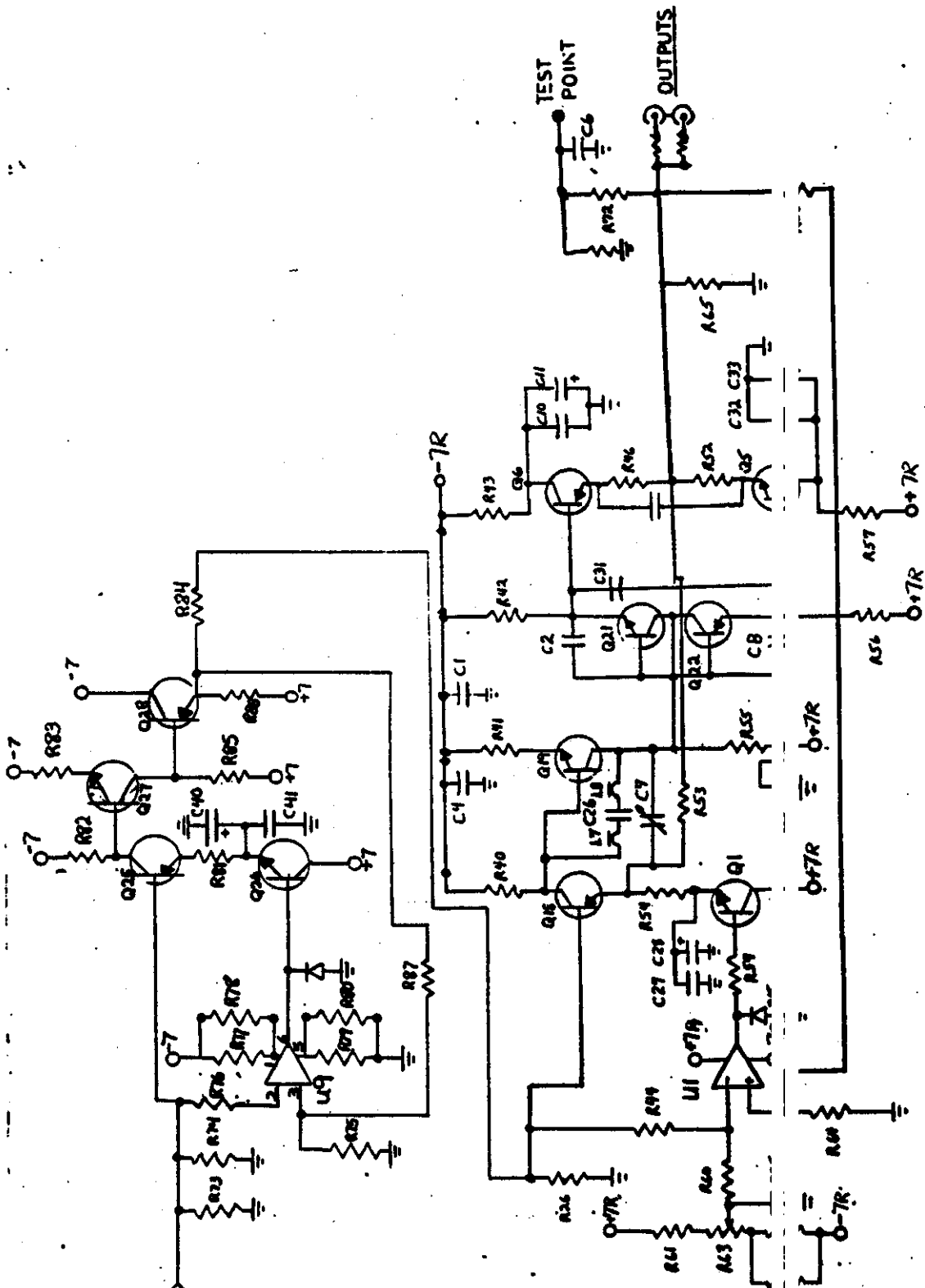

FROM
PAGE 1
2

