

MICHIGAN STATE UNIVERSITY
CYCLOTRON PROJECT

**A Thermoelectrically Cooled
Hall-Effect Magnetic Field Probe**

John A. Futhey

July 1963

Department of Physics
East Lansing, Michigan

ABSTRACT

A THERMOELECTRICALLY COOLED HALL-EFFECT MAGNETIC FIELD PROBE

by John A. Futhey

A hall effect magnetic fluxmeter to be used in a sector-focused cyclotron was designed and built. The indium arsenide Hall probe is cooled to about 0°C by two Bi_2Te_3 thermoelectric coolers, and these, in conjunction with a thermistor and Wheatstone bridge, maintain this temperature to within 0.01°C for periods of an hour or more. The overall accuracy of the present probe is such that the maximum error is two parts in 10^4 during hour-long periods. In addition to this, design changes are suggested which should increase this accuracy.

A THERMOELECTRICALLY COOLED
HALL-EFFECT MAGNETIC FIELD PROBE

By

John A. Futhey

A THESIS

Submitted to
Michigan State University
in partial fulfillment of the requirements
for the degree of

MASTER OF SCIENCE

Department of Physics and Astronomy

1963

ACKNOWLEDGMENTS

I should like to thank Dr. William P. Johnson for his valuable help and guidance during the entire course of this research. Thanks are also extended to Dr. R. D. Spence for his assistance with the field linearity studies.

I should particularly like to thank Mr. W. Harder and Mr. N. R. Mercer for their help in constructing the apparatus.

TABLE OF CONTENTS

	Page
INTRODUCTION	1
THEORY	3
Hall Effect	3
Thermoelectricity	7
CRITERIA OF APPARATUS OPERATION	10
DESCRIPTION OF APPARATUS	15
The Hall Probe	15
The Thermistors	17
The Epoxy Module	17
Temperature Regulation	18
Thermocoolers and Probe Mount	22
Regulated Current Supply	24
Hall Voltage Measurement	27
Test Magnet and Mechanical Feed System	27
Voltage Selector Switch	27
EXPERIMENTAL PROCEDURE	29
RESULTS	34
CONCLUSIONS	47
REFERENCES	49

LIST OF FIGURES

Figure	Page
1. Hall effect element showing geometry and electrical connections	5
2. Schematic diagram of thermoelectric cooler	5
3. Block diagram of Hall probe and associated control and measuring apparatus	11
4. Diagram of Siemens FC33 Hall probe. All dimensions in millimeters	16
5. Diagram of epoxy module showing placement of thermistors and copper plates	16
6. Schematic diagram of temperature control circuit and temperature monitoring circuit	19
7. Performance curve of thermoelectric cooler showing temperature of cold junction <u>vs.</u> cooler current	23
8. The epoxy module containing Hall probe and thermistors	25
9. The probe mount with one thermocooler and its heat sink to show the position of the module	25
10. Circuit diagram of Hall current regulator	26
11. Hall voltage <u>vs.</u> time for preliminary run	31
12. Hall current <u>vs.</u> time for run #1	35
13. Hall current <u>vs.</u> time for run #2	36
14. Temperature <u>vs.</u> time for run #1	37

Figure		Page
15.	Temperature <u>vs.</u> time for run #2	38
16.	Hall voltage <u>vs.</u> time for run #1	40
17.	Hall voltage <u>vs.</u> time for run #2 (Note change of scale at 5:00)	41
18.	Hall voltage as a function of probe temperature	43
19.	Hall voltage <u>vs.</u> magnetic field	45

I. INTRODUCTION

In order to calculate orbits for Michigan State University's new sector-focused cyclotron, accurate measurements of the magnetic field must be made. The object of this research is to design and construct a precision magnetic fluxmeter for this purpose. The general overall criterion of performance is a maximum error of $\pm 0.01\%$ for the entire system.

One of the aspects of sectored magnets as used in the cyclotron is high field gradients. For this reason, a Hall effect device was chosen because of its small field sampling area along with its high accuracy and good linearity.

The one limitation of a Hall probe is that like most semi-conductor devices, it is temperature sensitive. In order to operate within the small error prescribed, the temperature would have to be stable to better than 0.2°C . It is imperative therefore, to supply some kind of temperature stabilization system for the Hall probe.

Lind [1], at the University of Colorado, used a Hall probe as a fluxmeter for the sector-focused cyclotron there and cooled this probe with ice water. Most groups

(such as Dorst [2] and Hudson [3]) have chosen to heat their probes electrically and control the temperature with a bridge circuit. This author has incorporated a different kind of temperature control utilizing a second semi-conductor device, the thermoelectric cooler.

Thermoelectric cooling offers some advantages over other methods of temperature control. The coolers are small, they pump heat quickly, and there are no moving parts or complicated associative equipment (such as plumbing). There is an advantage of cooling over heating, although admittedly slight. The Hall probe is more efficient at lower temperatures and larger control currents can be used, which if used at higher temperatures, would damage the Hall probe.

The entire probe assembly is quite small and requires no involved thermal insulation -- all in all producing a fluxmeter having high accuracy and ease of operation.

II. THEORY

The Hall Effect

When a current I_H and magnetic field B are perpendicular in a crystal, an electric field E_H is produced, which is perpendicular to both I_H and B . This phenomenon is known as the Hall effect, after its discoverer, Dr. E. H. Hall.

Referring to Fig. 1, as electrons flow from 1 to 2 (Hall current), they will experience a lateral Lorentz force $F_m = evB$, where v is the average velocity of the electrons. This Lorentz force will cause a lateral drift of the electrons which in turn will set up an electric field E_H . When the electric force F_e , arising from E_H , equals the magnetic Lorentz force F_m , then the system will be in equilibrium. Now the electric field E_H is

$$E_H = \frac{V_H}{w} \quad (1)$$

where V_H is the Hall voltage, and w is the width between 3 and 4. The force on an electron arising from this field is

$$F_e = \frac{eV_H}{w} \quad (2)$$

From classical statistics, current density is defined as

$$j = nev \quad (3)$$

where n is the charge carrier concentration. Referring to the geometry of Fig. 1, if t is the thickness of the crystal, then the current density is

$$j = \frac{I_H}{tw} \quad (4)$$

or

$$evB = eE_H \quad (6)$$

Combining (6), (4), (3), and (2) gives

$$V_H = \frac{1}{ne} I_H B. \quad (7)$$

Now let $\frac{1}{ne}$ be defined as the Hall constant R_H , and V_H as the Hall voltage, and (8) is the operating equation for the Hall effect:

$$V_H = \frac{R_H}{t} I_H B. \quad (8)$$

If I_H is expressed in amps, V_H in volts, t in centimeters, R_H is $\text{cm}^3/\text{coulomb}$, and B in kilogauss, then (8) should be changed by a numerical factor to become

$$V_H = 10^{-5} \frac{R_H}{t} I_H B. \quad (9)$$

This is the form of the equation which will be used hereafter unless specifically stated otherwise.

The above derivation is actually valid only for metals.

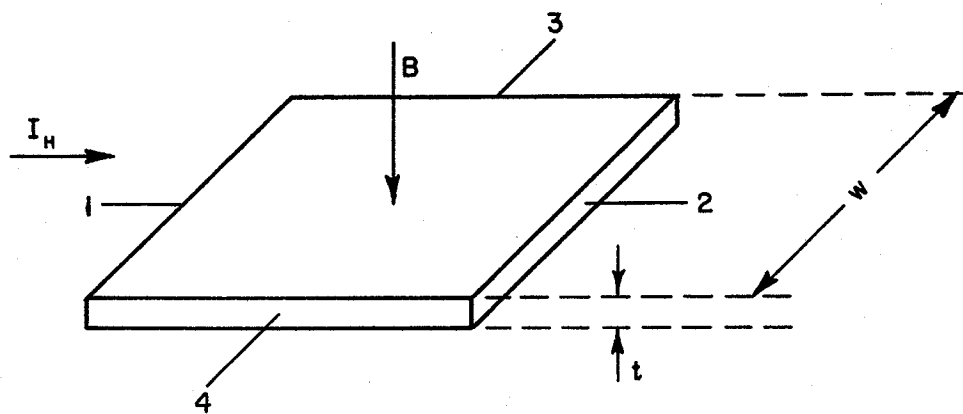

Fig. 1: Hall effect element showing geometry and electrical connections.

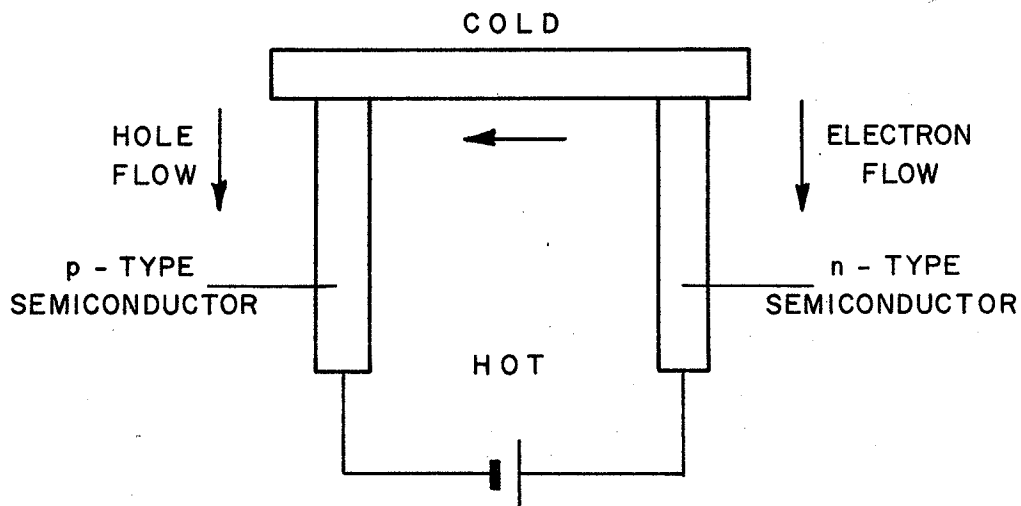

Fig. 2: Schematic diagram of thermoelectric cooler.

When dealing with semiconductors, R_H changes because of the presence of both holes and electrons as charge carriers.

Hilsum [4] shows that R_H for the general case of a semiconductor becomes

$$R_H = \frac{1 - b^2 c}{(1 + bc)^2} \frac{c}{ne} \quad (10)$$

where

$$n = pc, \quad (11)$$

and b is defined by

$$\mu_n = \mu_p b. \quad (12)$$

Here, p is the hole concentration, μ_n and μ_p are the electron and the hole mobilities respectively, and b and c are constants.

When the Hall voltage is fed into a low impedance (as is done in this research), the figure of merit is proportional to μ_n/n (Hilsum [4]). To have a high figure of merit along with a high output voltage (i.e., large R_H) it is clear that the substance should be a semiconductor with high carrier mobility and low carrier concentration.

There is a third important consideration besides carrier concentration and mobility, and that is the temperature sensitivity of the material. A semiconductor has its highest carrier mobility in the pure state, but in this state, the carrier concentration is highly temperature

dependent. The temperature dependence of carrier concentration can be markedly reduced by doping, which, however, causes a decrease in carrier mobility. Thus, for best operation, a compromise must be made.

Probably the best semiconductor for use as a flux-meter where high output and low temperature dependence are desired is indium arsenide. Chasmer and Cohen [5] have attributed the high mobility to small effective electron mass. They also suggest that the low temperature dependence of R_H is the result of an impurity conduction band which overlaps the normal impurity band. This apparently provides a continuous density of carriers, which is largely temperature independent.

Thermoelectricity

The theory which tries to explain the various thermoelectric effects is complex and incomplete. For this reason, only a general, relatively qualitative explanation of these effects will be given here. Ioffe [6] presents the theory in detail for those who are interested.

The two most important thermoelectric effects are the Seebeck effect and the Peltier effect. Basically, the Seebeck effect involves the production of a potential difference between the junctions of two different conductors

when these are at different temperatures. The relationship between ΔV and ΔT is dependent upon the materials used, this relationship being defined by

$$\lim_{\Delta T \rightarrow 0} \frac{\Delta V}{\Delta T} = \alpha \quad (13)$$

The term α is called either the Seebeck coefficient or the thermoelectric power.

The Peltier effect is roughly the opposite of the Seebeck effect. It consists of the generation or absorption of heat, at a rate Q , at the junction between two different conductors when a current I flows through them:

$$Q = \pi I \quad (14)$$

where π is the Peltier coefficient.

That the two effects are closely related can be seen by the simple relationship between their respective coefficients (Goldsmid [7]):

$$\pi = \alpha T. \quad (15)$$

Fig. 2 shows a schematic of a simple thermoelectric refrigerator. Two semiconductors, one p-type and the other n-type, are joined to a DC battery as shown. With the direction of current as indicated in Fig. 2, the electrons will flow from the cold junction to the hot junction in the n-type semiconductor. The carriers in the p-type branch are

holes, which will also flow from cold to hot junction. These carriers transfer heat energy from the cold junction to the hot junction, this heat being dissipated by a heat sink.

Goldsmid [7] develops a figure of merit for a thermoelectric cooler which is

$$z = \alpha^2 \frac{\sigma}{K} \quad (16)$$

where α is the thermoelectric power, σ is the electrical conductivity, and K is the thermal conductivity. A high σ is desired in order to minimize the Joule heating, half of which will go to the cold junction. At the same time a low thermal conductivity, K , is desired in order to minimize the heat flow from hot to cold junction.

The thermoelectric coolers used in this research are made of bismuth telluride. This is produced in a p-state, and the n-state is obtained by doping with indium or arsenic (Browning [8]). The figure of merit for a Bi_2Te_3 thermoelectric cooler is 2.0 whereas the next best material, lead telluride, has a figure of merit of 1.3 (Goldsmid [7]).

III. CRITERIA OF APPARATUS OPERATION

Fig. 3 is a block diagram of the apparatus used in the experiment. Functionally, the components may be placed in three main groups: Hall current supply, temperature regulation, and Hall voltage measurement and reading system.

The Hall current supply consists of the Hall current regulator and its two associated power supplies. This system provides a stable current of 85 milliamps to the control side of the Hall probe.

The temperature regulation system consists of a thermistor, the thermoelectric bridge and amplifier, with its two associated power supplies, and the two thermoelectric coolers. This system cools the Hall probe to 0°C , and must maintain this temperature to better than $\pm 0.1^{\circ}\text{C}$.

The third system includes the Hall probe itself, an amplifier, a digital voltmeter, and a card punch. The function of this system, of course, is to read and register the voltage which is proportional to the magnetic field being measured.

The experiment was initially designed to obtain magnetic field measurements having a maximum error of $\pm 0.01\%$.

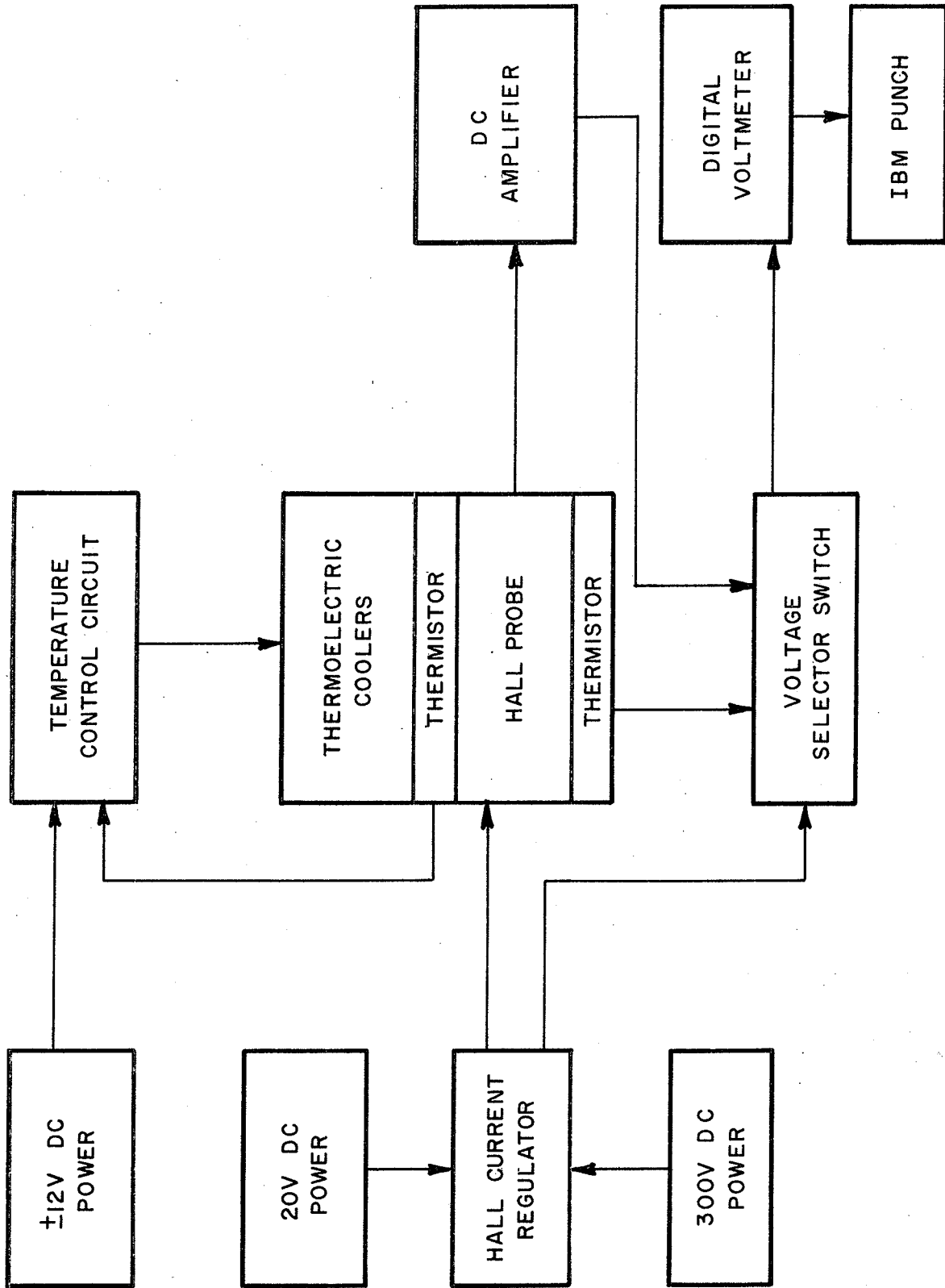

Fig. 3: Block diagram of Hall probe and associated control and measuring apparatus.

Using this as a basic criterion, one can determine criteria for the individual components.

Because the output of the Hall probe is directly proportional to the control current, it is clear that this current should be stable to within one part in 10^4 .

An analysis of temperature stability performance is not as simple as is the control current, but a theoretical evaluation of the process can give good operational criteria. Under normal circumstances, external thermal fluctuations will be slow enough and small enough that the temperature control system can correct for them. The major thermal problem is one of internal Joule heating in the Hall probe caused by changes in output power.

As the probe moves across the face of the magnets in the region of a high gradient, the field will change very rapidly by some amount, ΔB . According to (9), this will cause a change in Hall output voltage of

$$\Delta V_H = \frac{10^{-5} R_H}{t} I_H \Delta B. \quad (17)$$

Corresponding to this will be a change of Joule heating

$$\Delta P = \frac{2V_H \Delta V_H + (\Delta V_H)^2}{R_o} \quad (18)$$

where R_o is the output impedance of the Hall probe (about 3.5Ω).

The thermocoolers must be able to pump this ΔP with a minimum momentary temperature increase ΔT . The Hall constant R_H has a temperature dependence of $-0.04\%/^{\circ}\text{C}$; therefore, if R_H changes by one part in 10^4 , this will correspond to a ΔT of 0.25°C . This is the maximum allowable ΔT , because if R_H changes one part in 10^4 , so does the magnetic field reading.

The most that the magnetic field will change between readings is about one kilogauss which would correspond to a ΔV of about .03 volts. Therefore, from (18),

$$\Delta P_{\max} \cong 10 \text{ milliwatts.} \quad (19)$$

So a temperature control specification is finally arrived at, namely, that a ΔP of 10 milliwatts Joule heat must be pumped without the temperature changing by more than 0.25°C .

Besides this primary temperature effect, a secondary temperature effect is present. The input resistance R_i of the Hall probe has a temperature coefficient of $0.2\%/^{\circ}\text{C}$, hence a change in temperature will cause a change of Joule heat produced by the control current.

Assume that the temperature is allowed to change by $\Delta T = 0.25^{\circ}\text{C}$, then the input resistance will change by

$$\Delta R_i = 0.2\% \times \Delta T \cdot R_i \quad (20)$$

or, since $I \approx .1$ amp, $\Delta P = 0.025$ milliwatts, which may be neglected when compared to the primary effect of 10 milliwatts.

The criterion for the third function group, that dealing with measurement and recording is again quite clear. The output of the Hall probe is fed into an amplifier, a digital voltmeter, and a card punch. As long as these three components are accurate to better than 0.01%, then the criterion is met. The three components are good commercial systems, comfortably meeting this requirement.

IV. DESCRIPTION OF APPARATUS

The Hall Probe

The Hall probe used in this research is a Siemens model FC 33. This device is characterized by low input and output impedance, high sensitivity, good linearity, and low temperature dependence. Fig. 4 shows the dimensions of the unit.

The open circuit sensitivity of the unit is 0.145 v/amp kilogauss, while the input and output impedances are ~ 5 and 3.5 ohms, respectively. The temperature coefficient for the Hall constant is $-0.04\%/^{\circ}\text{C}$, whereas the same coefficient of the internal resistance is $0.2\%/^{\circ}\text{C}$.

There is a null voltage (i.e., a signal output for no magnetic field) which is caused by certain unavoidable inaccuracies in the construction of the unit. This is supposed to be less than 10^{-4} volts assuming a control current of 100 milliamps.

The indium arsenide sensitive element is enclosed in sintered ceramic and resin molding to provide some mechanical rigidity to the unit.

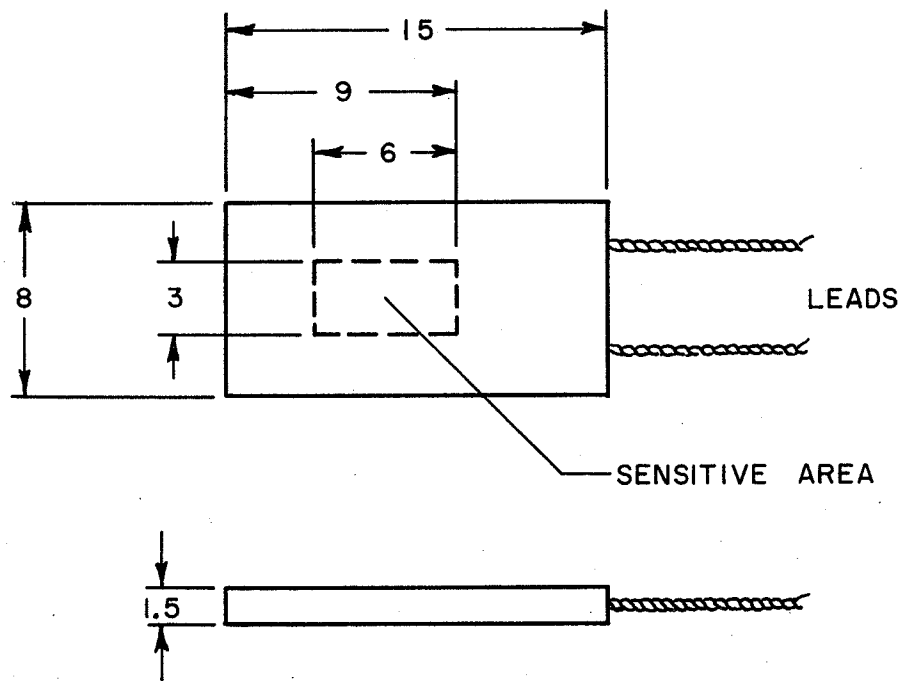

Fig. 4: Diagram of Siemens FC33 Hall probe. All dimensions in millimeters.

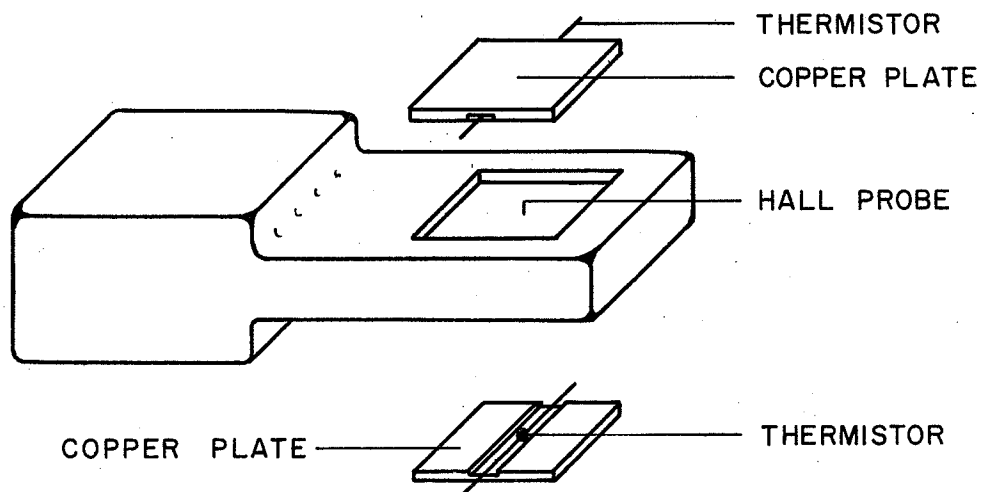

Fig. 5: Diagram of epoxy module showing placement of thermistors and copper plates.

The Thermistors

Gulton model 32CH1 glass bead thermistors were used to sense the temperature. These were chosen because of their fast (one second) response time. They are further characterized by a 2K resistance at room temperature. In order to have such a fast response time, the thermistors are small (0.014 in. dia.). The diameter of the leads is also minimized so that they provide low heat conduction to the sensitive element. The resultant tiny components require the exercise of extreme care and patience when working with them.

The Epoxy Module

It was found that breakage was a major problem in working with the fragile Hall probe and the minuscule thermistors. For this reason it was decided to package the Hall probe and thermistors in an epoxy module [9] together with a plug-in type electrical connector (see Fig. 8). This provides two additional advantages. During a normal research program, changes and alterations are constantly being made, and the plug-in feature of the module allowed for its easy removal and replacement. The other attribute of the epoxy encapsulation was one of moisture-proofing the components. Because the operating temperature is about 0°C, water would have condensed on the components

had the module principle not been used.

Temperature Regulation

The temperature control circuit diagram is shown in Fig. 6. This circuit consists of a Wheatstone bridge one leg of which is one of the thermistors. This thermistor is mounted in the epoxy module next to the Hall probe. The signal from the bridge goes to one input of a Philbrick P65 solid state differential amplifier. A reference voltage and 10 turn Helipot provide the other input to the P65, thus allowing the operating temperature to be selected by setting the Helipot. The output of the P65 drives a Philbrick P66 current booster, which increases the current output of the P65 twenty times. The output of the P66 is then fed to a power amplifier which supplies the several amps of current to the low impedance thermoelectric coolers.

In addition to the temperature control system, Fig. 6 shows the temperature monitoring circuit. This is a mercury battery with a 202K resistor and thermistor in series. A voltmeter is connected across the thermistor, this voltage reading being proportional to the temperature. The temperature-voltage characteristics of this system can be easily derived. The voltage V_1 , across the thermistor is

$$V_1 = iR_1, \quad (22)$$

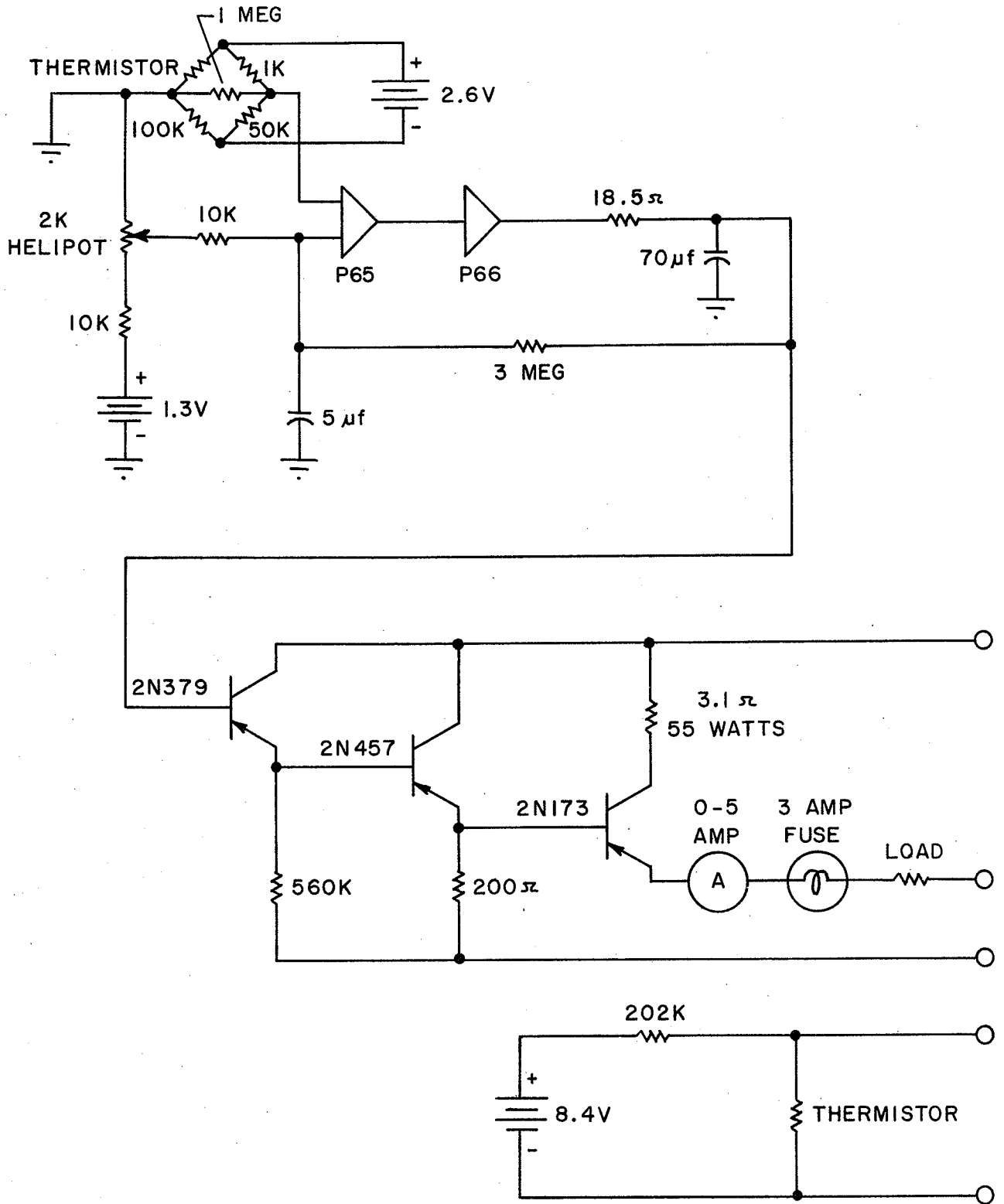

Fig. 6: Schematic diagram of temperature control circuit and temperature monitoring circuit.

and the battery voltage V_2 is

$$V_2 = i(R_1 + R_2) . \quad (23)$$

Combining (22) and (23) and solving for R_1 gives

$$R_1 = \left(\frac{R_2}{V_2 - V_1} \right) V_1 . \quad (24)$$

Now the temperature coefficient of the thermistor is

-4.3%/°C, or

$$\Delta R_1 = .043 R_1 \Delta T . \quad (25)$$

But from (24),

$$\Delta R_1 = \left(\frac{R_2}{V_2 - V_1} \right) \Delta V_1 . \quad (26)$$

So, combining (25) and (26), one finds that

$$\frac{R_2}{V_2 - V_1} V_1 = .043 R_1 \Delta T . \quad (27)$$

Substituting the expression for R_1 as given in (24) and

(27) and simplifying gives

$$\Delta T = \frac{\Delta V_1}{.043 V_1} \quad (28)$$

The combined system of the temperature control circuit, the thermoelectric coolers, and the sensing thermistor was highly unstable when first assembled. With the gain of the amplifier set high enough to provide good error correction, large oscillations developed in the circuit.

The oscillations would cease only at the expense of decreasing the gain to the extent that the circuit was ineffective. At first the electronics were suspect, but it soon became apparent that the fault was in the epoxy module.

The time constant of the thermistor's response to a change in temperature in the Hall probe was measured and found to be about 12 seconds. Next, a change of temperature was produced in the thermoelectric coolers and the time constant of the thermistor response was measured and found to be ~100 sec. It was, therefore, apparent that the disparity between the two time constants was producing the instability.

To solve the problem, two squares of the epoxy were cut out of the module just above and below the Hall probe, using a sharp, hot soldering iron. These spaces were then filled with copper plates (see Fig. 5). Grooves were milled in the copper and electrically insulated with varnish. Then the thermistors were placed in the grooves and more varnish applied.

The time constant of the probe with the copper slugs was measured and found to be about 30 seconds from Hall unit to thermistor, and 35 seconds from coolers to thermistor. With this arrangement, a gain of 300 in the amplifier could be used with no troublesome oscillations.

Thermocoolers and Probe Mount

Pesco model 094492-010 thermocoolers were used as the cooling device in this research. These are bismuth telluride, low current, eight couple, single-stage units, $\frac{1}{2}$ " x $\frac{1}{2}$ " x $\frac{3}{8}$ ". The hot and cold plates are copper, electrically insulated from the thermoelectric couples by a metalized ceramic having a high thermal conductivity. The epoxy module was sandwiched between the two coolers to provide maximum thermal stability.

The heat load that the thermocoolers have to contend with can be approximated in the following way. Nearly all heating in the probe arises from the Joule heating of the control current. The current is $\approx .085$ amps, and the resistance of the Hall probe to this current is 5 ohms. So, slightly over 400 milliwatts of heat are generated. Since two coolers are used, this is 200 mW heat load per cooler. Fig. 7 shows a performance curve for one cooler operating in free air with a 27°C (room temperature) heat sink, and a 200 mW load [10].

It should be noted that a temperature of -10°C could be obtained. The performance curve is flat near -10°C , however, and so a large change in current would be required to compensate for a small change in temperature. This would

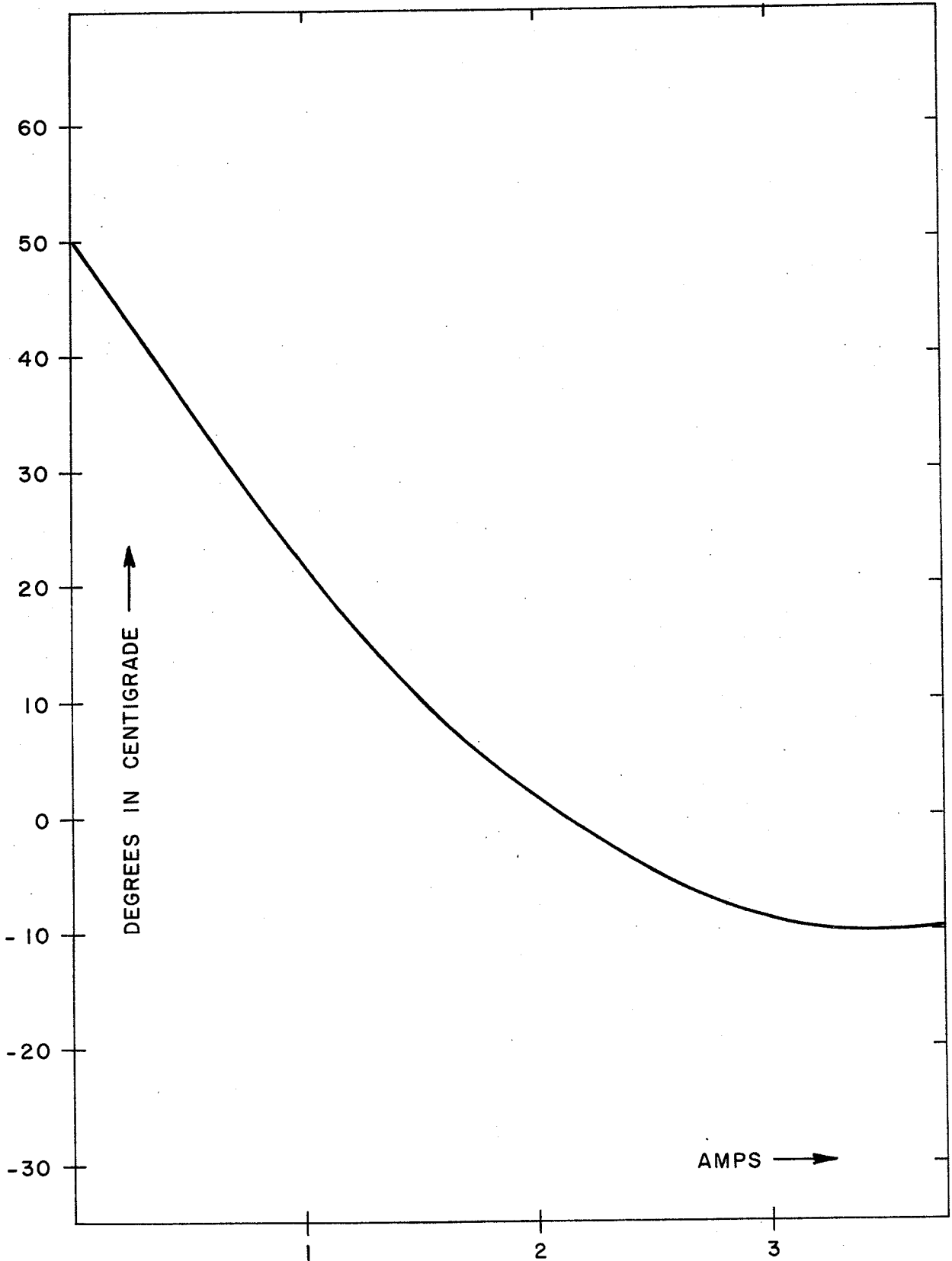

Fig. 7: Performance curve of thermoelectric cooler showing temperature of cold junction vs. cooler current.

be asking too much of the temperature regulation system. For this reason, the operating temperature was chosen to be about 0°C at which point a ΔT of 1°C could be corrected for by a ΔI of only .06 amps.

The thermocoolers were soldered to 2" x 3" x 1/8" copper plates (heat sinks) using Woods metal as solder. A low temperature melting solder must be used since temperatures in excess of 100°C will ruin the coolers.

Fig. 9 shows the probe mount with the positioning of the thermocoolers and Hall probe module. The design of the mount was dictated by the size and geometry of the test magnet and associated equipment.

Regulated Current Supply

Fig. 10 is a schematic diagram of the regulated current supply which supplies 85 milliamps of DC current to the input of the Hall probe. A Philbrick USA-3 operational amplifier is the main component of the circuit and requires both 6VAC filament power and ± 300 V DC from a separate regulated power supply. In addition, there is a 20-volt, DC-power supply which provides the load current.

The leads across the 1% 10Ω resistor afford a means of monitoring the current output, as well as furnishing the feedback voltage for the current regulation.

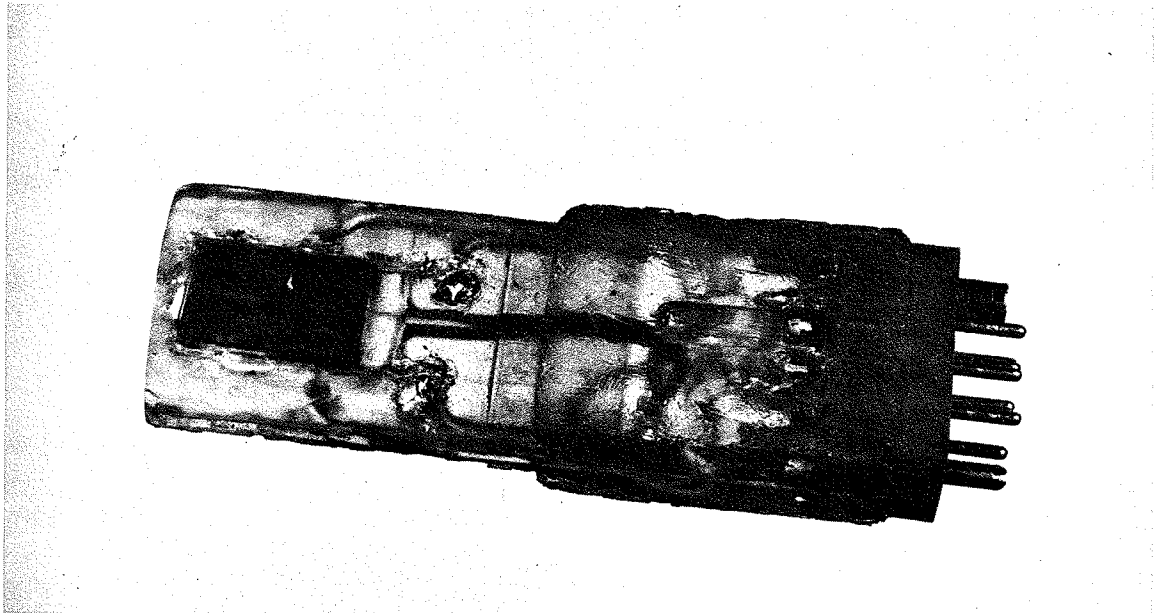

Fig. 8: The epoxy module containing Hall probe and thermistors.

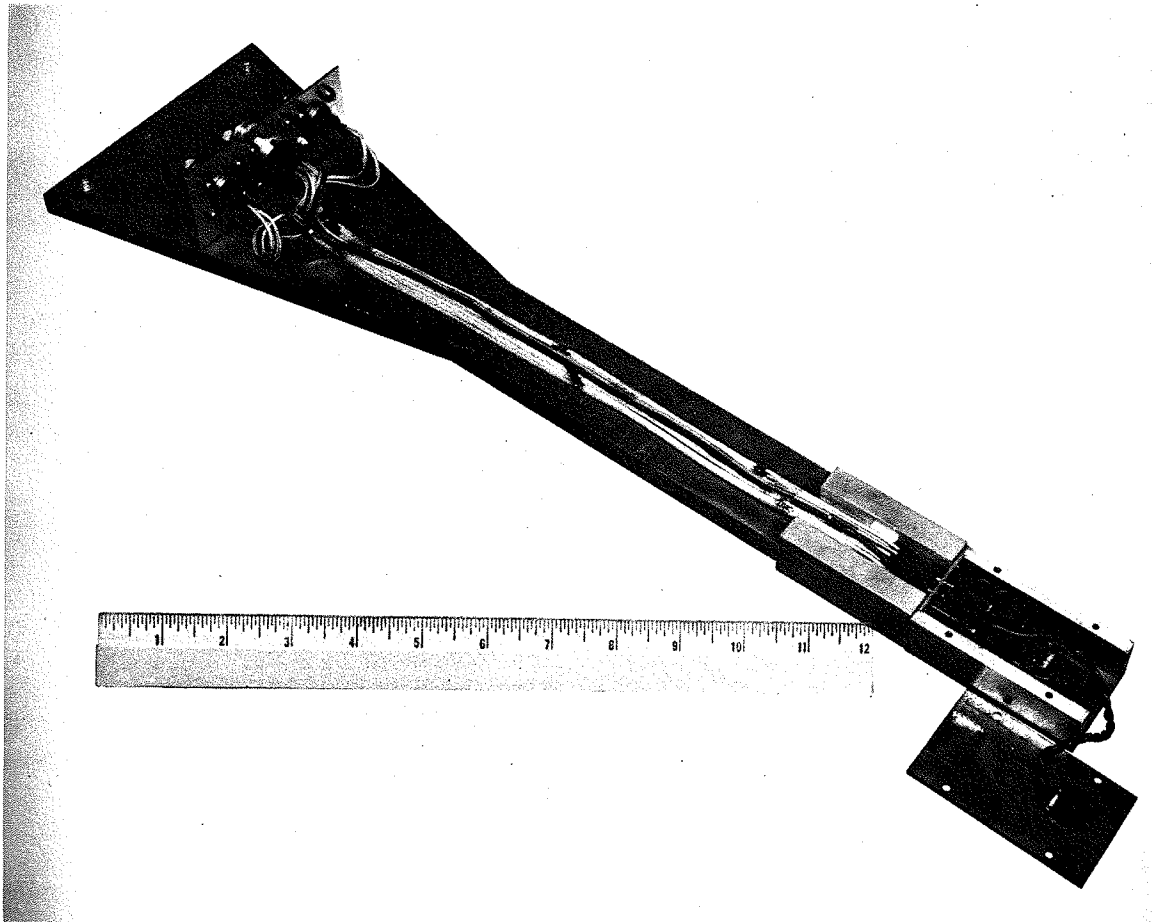

Fig. 9: The probe mount with one thermocooler and its heat sink removed to show the position of the module.

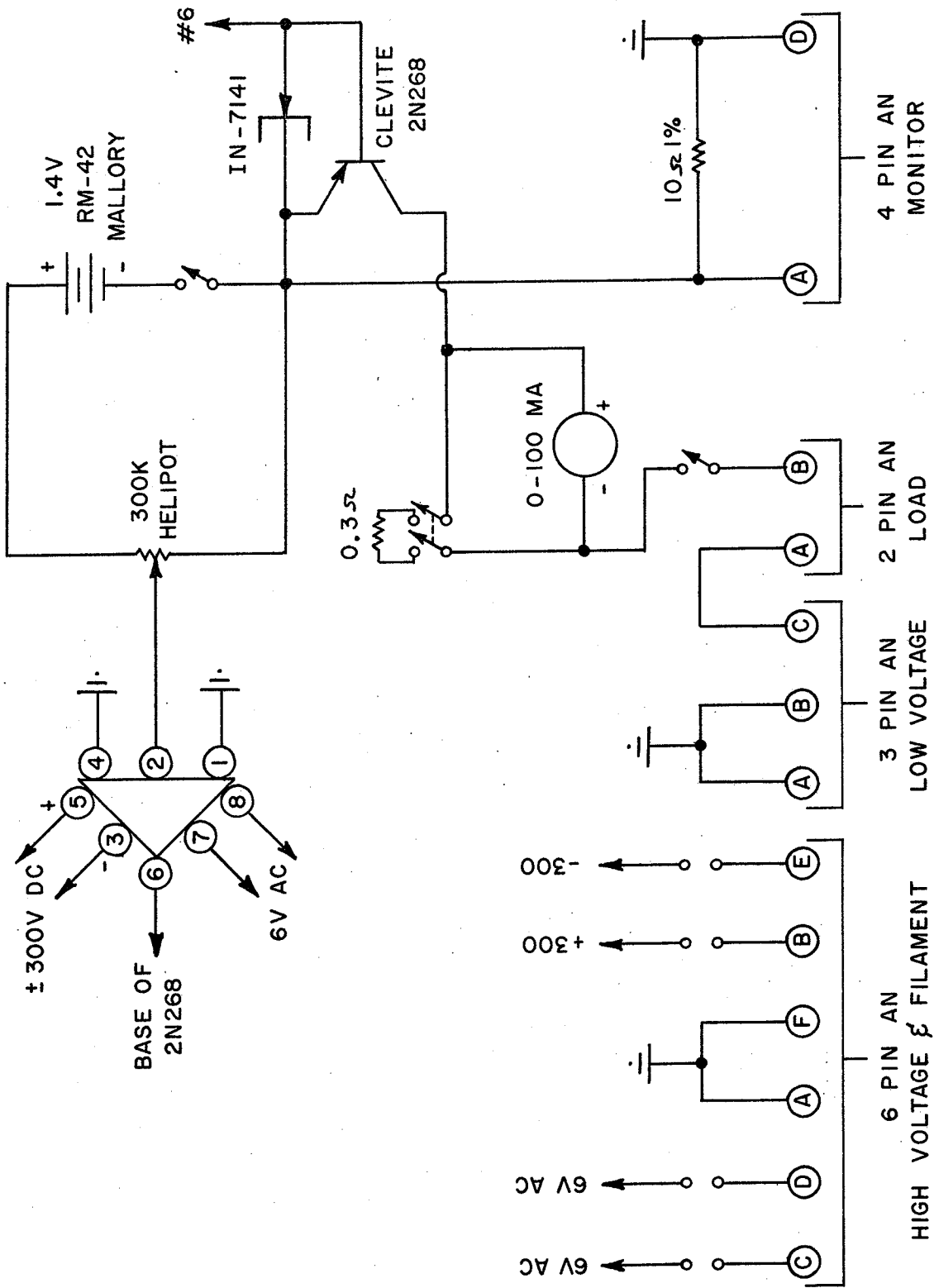

Fig. 10: Circuit diagram of Hall current regulator.

Hall Voltage Measurement

The Hall voltage measurement apparatus consists of an amplifier, a digital voltmeter, and a card punch. A Keithly model 149 milli-microvoltmeter with a gain of 100 is used to amplify the Hall voltage. The digital voltmeter is a Non Linear Systems model V35A. The output of this voltmeter is fed to a standard IBM card punch.

Test Magnet and Mechanical Feed System

A 1:6 scale model of the sectored cyclotron magnet and semiautomatic positioning device were available for testing the Hall probe. However, after the Hall probe and all of its associated apparatus were operational, an unfortunate discovery was made. The magnet was too inaccurate to test the Hall probe. The magnet regulation was only good to about 0.1%, thereby prohibiting the possibility of checking the Hall probe to the one part in 10^4 accuracy desired.

Voltage Selector Switch

A voltage selector switch is provided to select the voltage associated with Hall output, Hall current, or temperature, and feed it to the digital voltmeter. With this switch one can quickly look at either V_H , I_H , or T. Included in this circuit is a 25 ohm matching resistor

across the output of V_H . This resistor provides the necessary low impedance load on the Hall probe to provide maximum linearity of V_H vs. field.

V. EXPERIMENTAL PROCEDURE

The original plan of the experiment was to check the probe under circumstances similar to those which will be used with the cyclotron. This meant using the model cyclotron magnet and the automatic probe positioning device. With this apparatus it would be possible to map the field for the magnet several times and see whether or not the results were consistent within the allowable error. This, of course, was not done because the magnetic field was not stable.

The instability of the model magnet was not the only problem, however, and as a result of these various problems, the design of the experiment was changed. Before discussing the change in the experiment, these other problems will be discussed.

As mentioned previously, the zero field output of the Hall probe should only be a few microvolts. Because of a blunder, the zero field output of the Hall probe is nearly 50 millivolts. This large null voltage resulted when a large current pulse was accidentally passed through the output leads of the Hall probe. This did not seem to affect the sensitivity or the linearity of the probe, but

it apparently affected the temperature dependence of the Hall constant. This null voltage can be compensated for by a simple circuit, and although this was tried, it was discarded because the potentiometers in the circuit were unstable. For the purposes of the experiment the null voltage caused no concern.

The voltage selector switch was inaccurate when used to measure V_H . Fig. 11 shows a graph of V_H vs. time at zero field. There is a large, fairly steady drift of V_H , even though the Hall current, magnetic field, and temperature were relatively constant. The drift can be explained by the measurement procedure. Each time that V_H was measured, I_H and T were also measured. This meant that the voltage selector switch was cycled each time a series of readings were taken. Apparently the wiping action of the switch contacts altered the circuit resistance enough to cause the drift. To substantiate this hypothesis, the switch was left on the V_H setting for 30 minutes and not disturbed. This is the interval between A and B in Fig. 11. During this time there was no drift, so it was decided not to use the voltage selector switch when measuring V_H .

The final piece of apparatus to be discarded (at least partially) was the digital voltmeter. This instrument was suspected by other research personnel of inaccuracy,

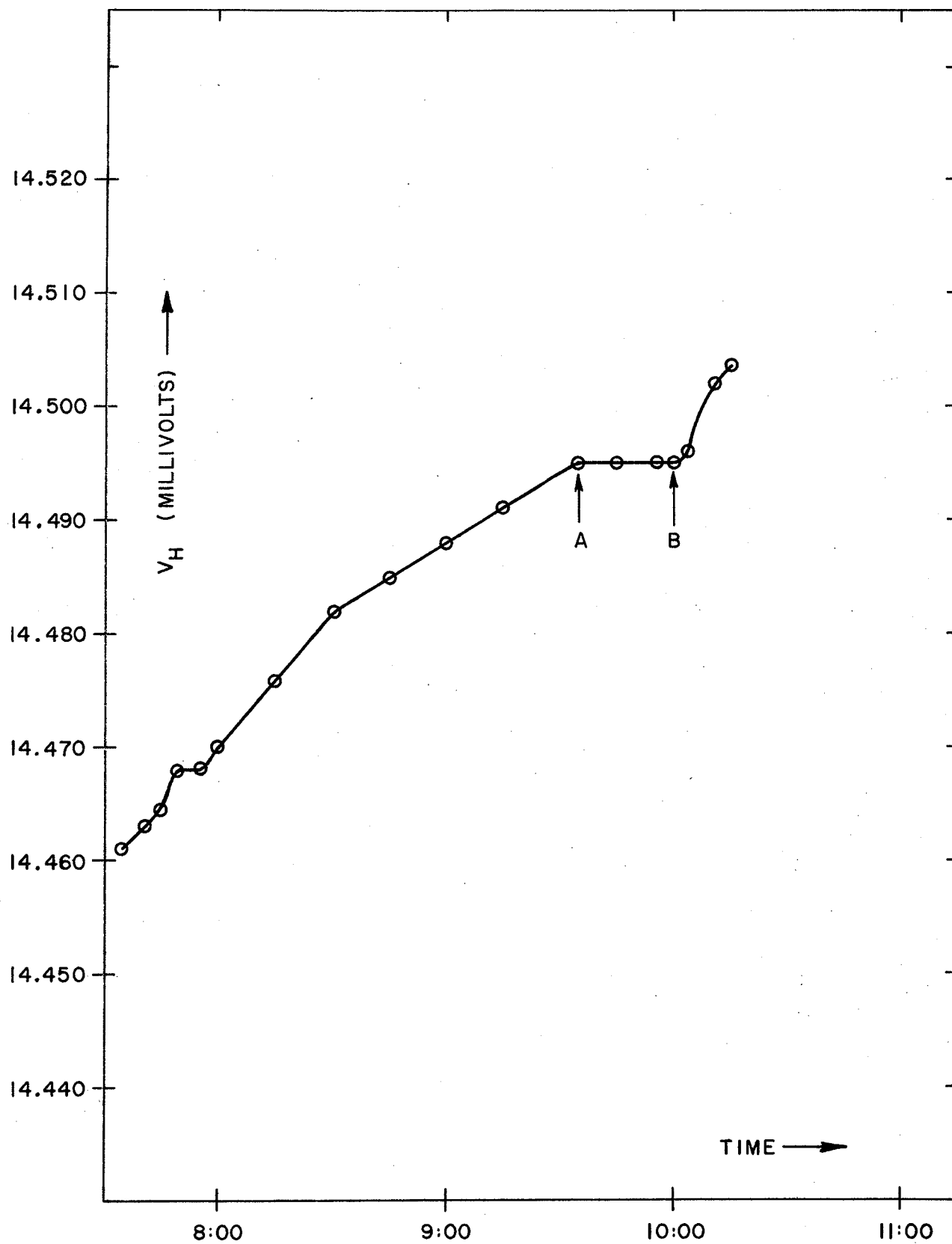

Fig. 11: Hall voltage vs. time for preliminary run.

especially when the input signal was constantly changing by small amounts. It was stable when used with a steady input such as the voltages associated with the temperature and Hall current, but did not provide reproducible results for V_H .

The change in apparatus necessitated a compromise regarding the design of the experiment. It was felt that if the various components were stable under static and artificially imposed dynamic conditions, then the system as a whole should function properly as a fluxmeter. Of particular interest is the temperature stability, because this is the unique feature of this research.

With the foregoing remarks in mind, the testing of the Hall probe consisted first of recording the temperature, Hall current and Hall voltage, both in and out of a magnetic field, as a function of time. Secondly, the effect that a change in temperature has on the Hall voltage was determined. Thirdly, the effect that a sudden change in magnetic field has on the temperature was noted, and finally a linearity study of V_H vs. B was made.

The majority of the data obtained for this research was the result of two runs, which for simplicity, shall be called run #1 and run #2. Run #1 was carried out in zero field with the Hall current (actually a voltage proportional

to this current) and probe temperature (again a proportional voltage) measured with a precision potentiometer. The Hall voltage was measured with the digital voltmeter. Because it is difficult to average out a rapid sequence of digital voltmeter readings visually, a semi-automatic procedure was used. Ten readings, each about three seconds apart, were punched on cards, and the average of these readings was taken as the value for that point. The relatively large and random errors observed in this process were responsible for the change in procedure for the second run. In run #2, the Hall voltage was measured with the potentiometer while the digital voltmeter was used to measure the Hall current and temperature voltages. Run #2 was done with the probe in a 1.4 kilogauss field supplied by an Alnico permanent magnet. After four hours in the field, the magnet was removed and readings in zero field were continued for an additional hour.

VI. RESULTS

Fig. 12 shows the Hall current vs. time for run #1. If 0.84168 is taken as the average value, then the variation from this is ± 0.00004 , or an error of five parts in 10^5 . Fig. 13 shows current vs. time for run #2. Because the digital voltmeter was used in this run to measure this current, only four significant places were obtained. Just two values of current were observed: 0.8418 and 0.8419. It, therefore, seems reasonable to assume the error in run #2 was something less than one part in 10^4 , although how much less cannot be ascertained. From these results one may conclude that the Hall current supply meets its operational criterion.

The plot of temperature vs. time for run #1 is shown in Fig. 14. It can be seen that 0.28060 is the average value, and the variation is ± 0.0001 , or an error of about four parts in 10^4 . During the longer period of run #2, including an abrupt change in magnetic field, the plot in Fig. 15 shows an error of ± 0.0003 for an average value of 0.2829. This is an error of about 12 parts in 10^4 for the full five hours. For a shorter period, say from 4:00 to

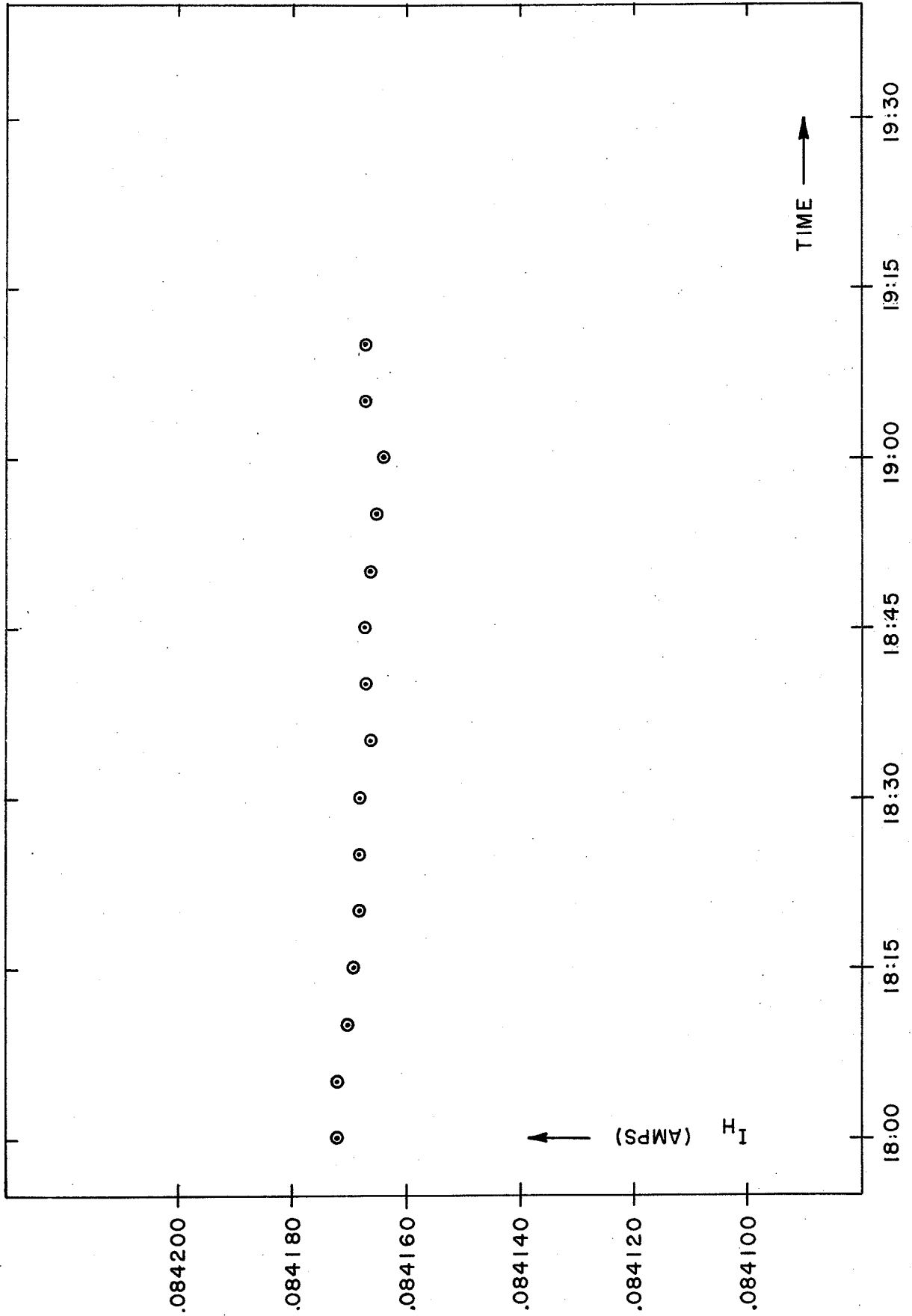

Fig. 12: Hall current vs. time for run #1.

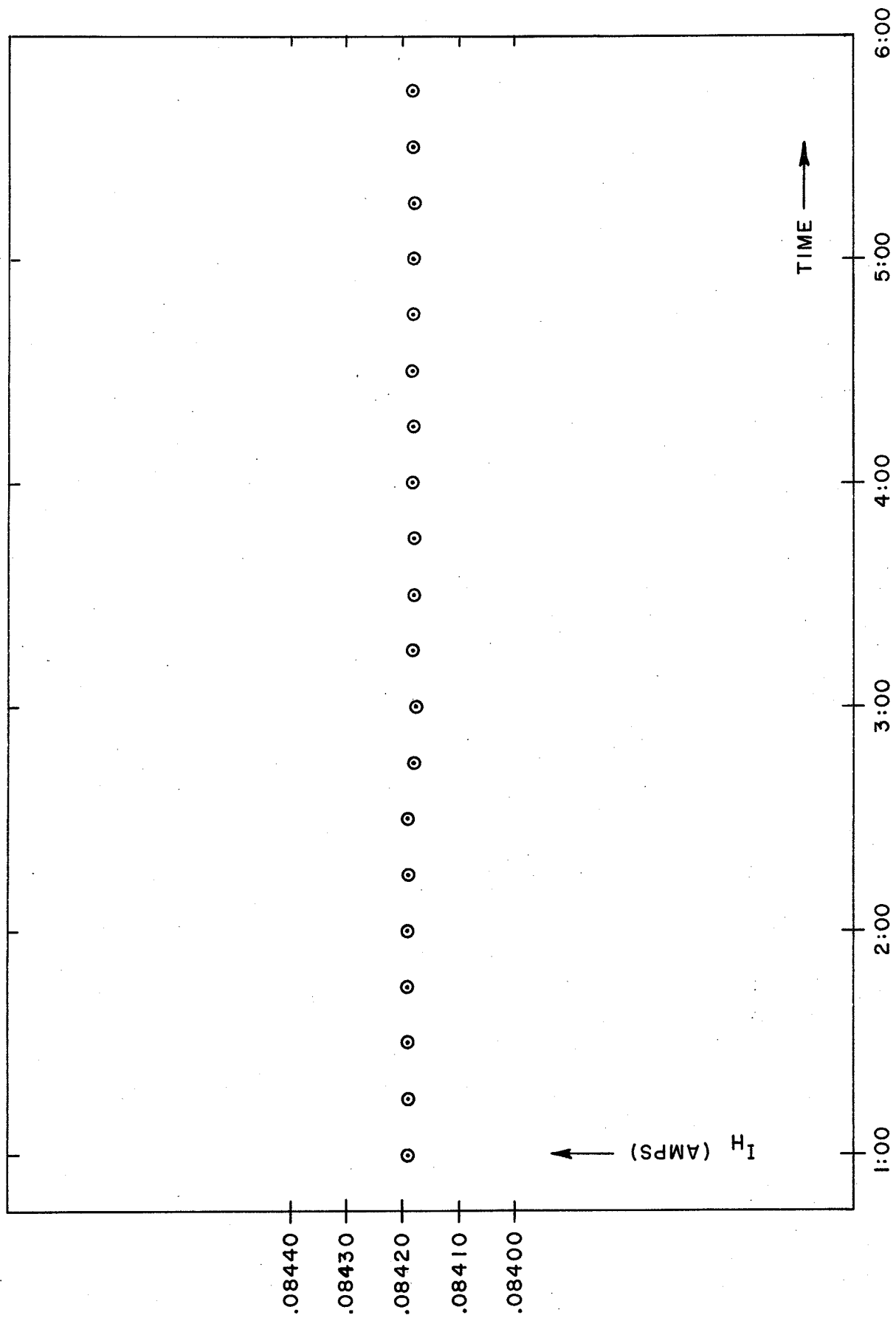

Fig. 13: Hall current vs. time for run #2.

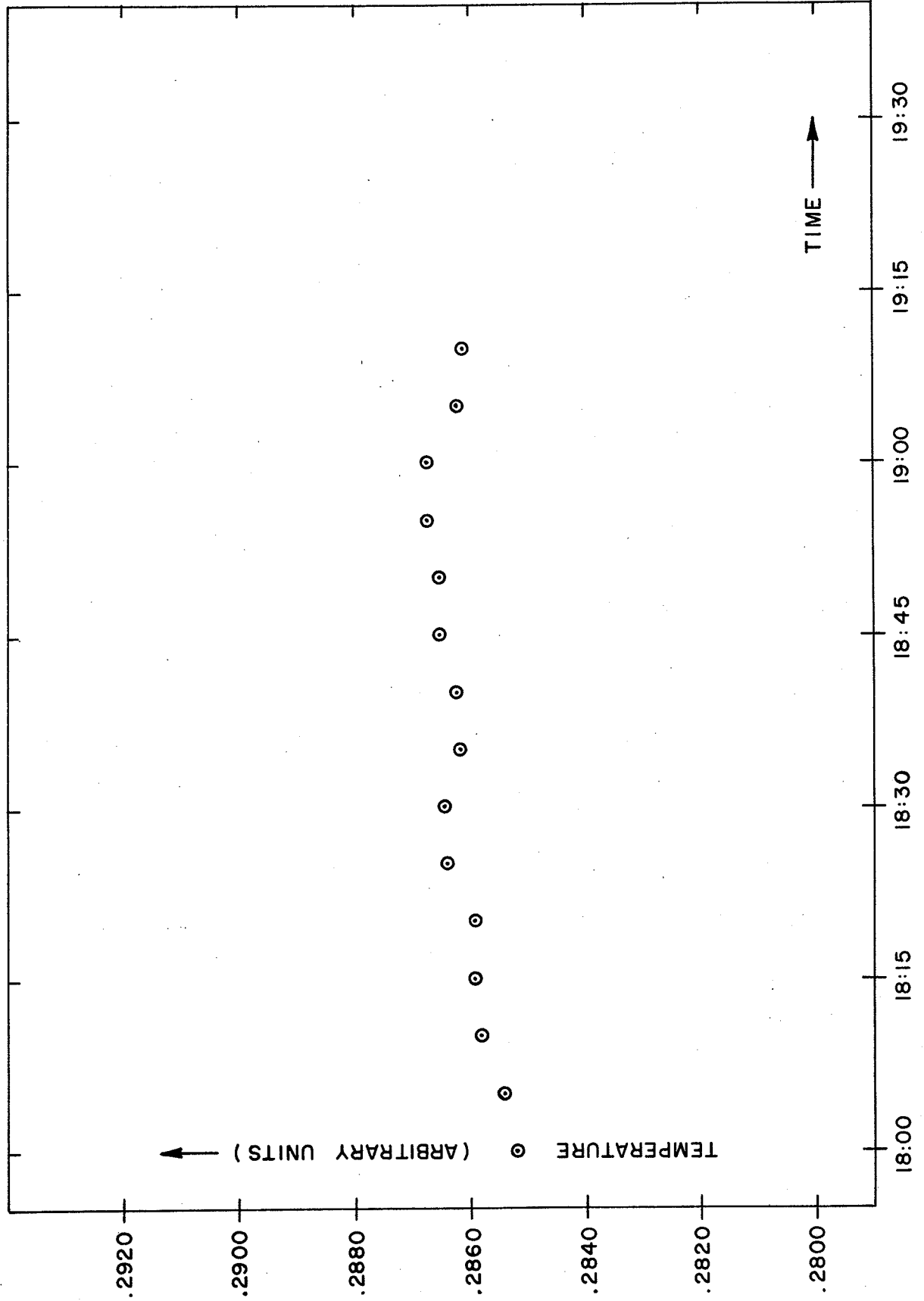

Fig. 14: Temperature vs. time for run #1.

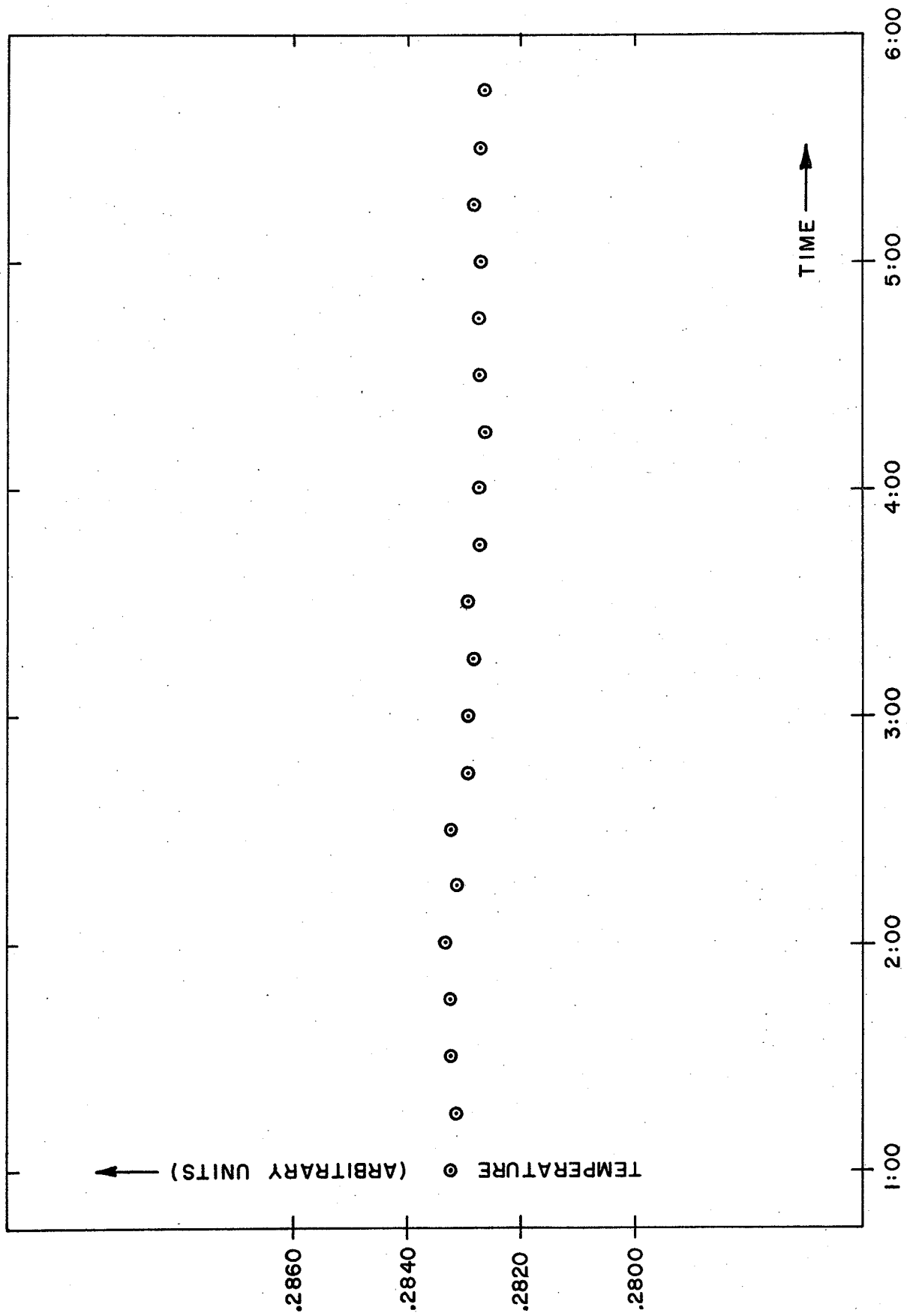

Fig. 15: Temperature vs. time for run #2.

5:00, the error is again four parts in 10^4 . It should be noted that according to (28), a change in the voltage associated with temperature of 0.0001 volts is equivalent to an actual temperature change of 0.01°C . This means that over the period of an hour, the temperature of the probe is held constant to $\pm 0.01^\circ\text{C}$!

The plot of Hall voltage vs. time for run #1 is shown in Fig. 16. Even though during this time the Hall current and temperature were very stable, large fluctuations were observed in V_H . This was what prompted the change in procedure in run #2.

At first glance, the results of V_H vs. time for run #2 shown in Fig. 17 are discouraging, but possibly not. Examining V_H with the field off (5:00 to 6:00) shows a very nice result. During this hour, the error in V_H is about six parts in 10^5 which is comparable to the error in the Hall current. The question is, what happened during the previous four hours where there was a steady drift totaling about 0.1%?

Run #2 was started at 1:00 a.m. and continued to 6:00 a.m., during which time the ambient temperature in the laboratory decreased because of the natural cooling of the night. Unfortunately, the temperatures were not recorded, but a 5°C decrease in temperature is a reasonable approximation.

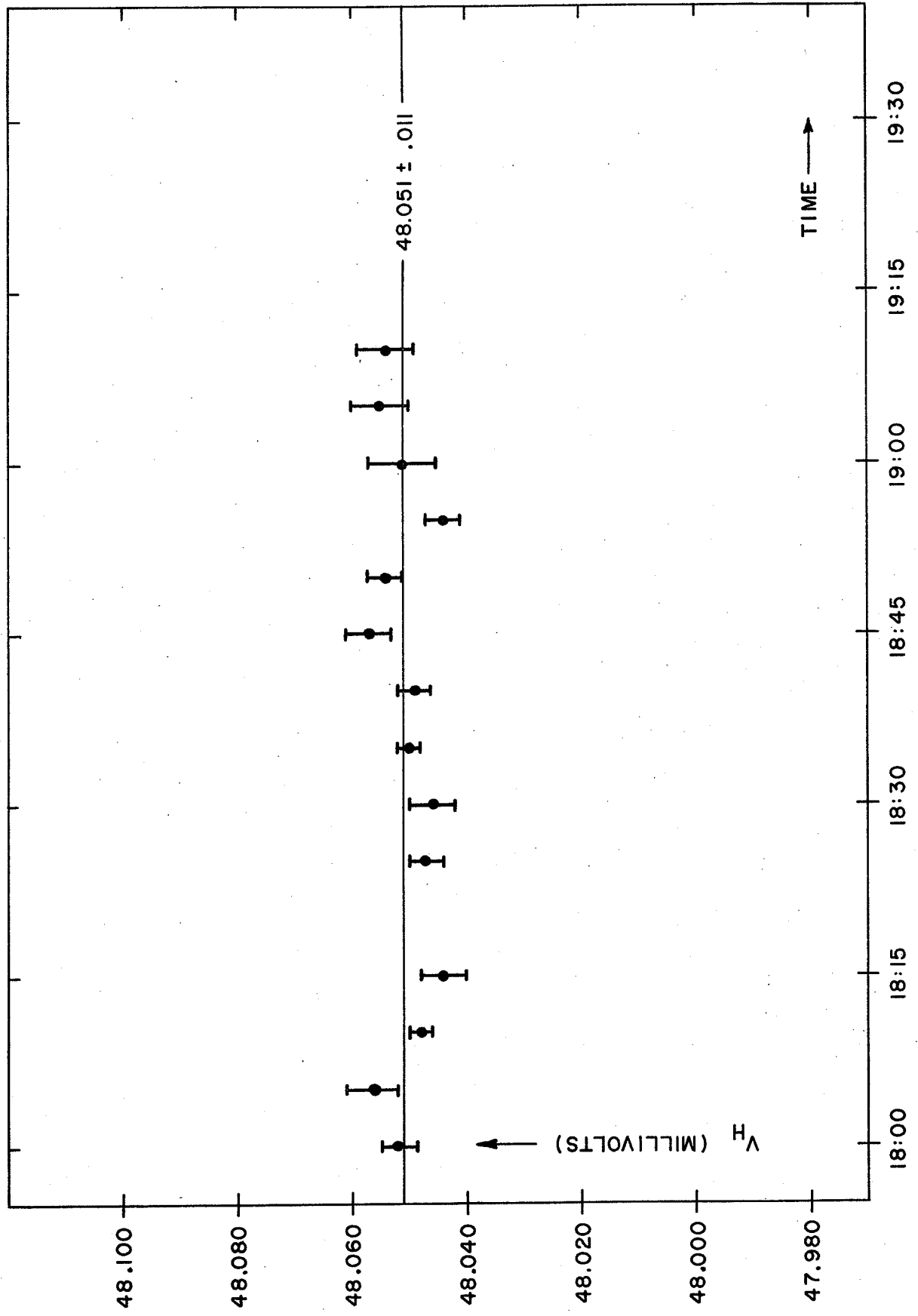

Fig. 16: Hall voltage vs. time for run #1.

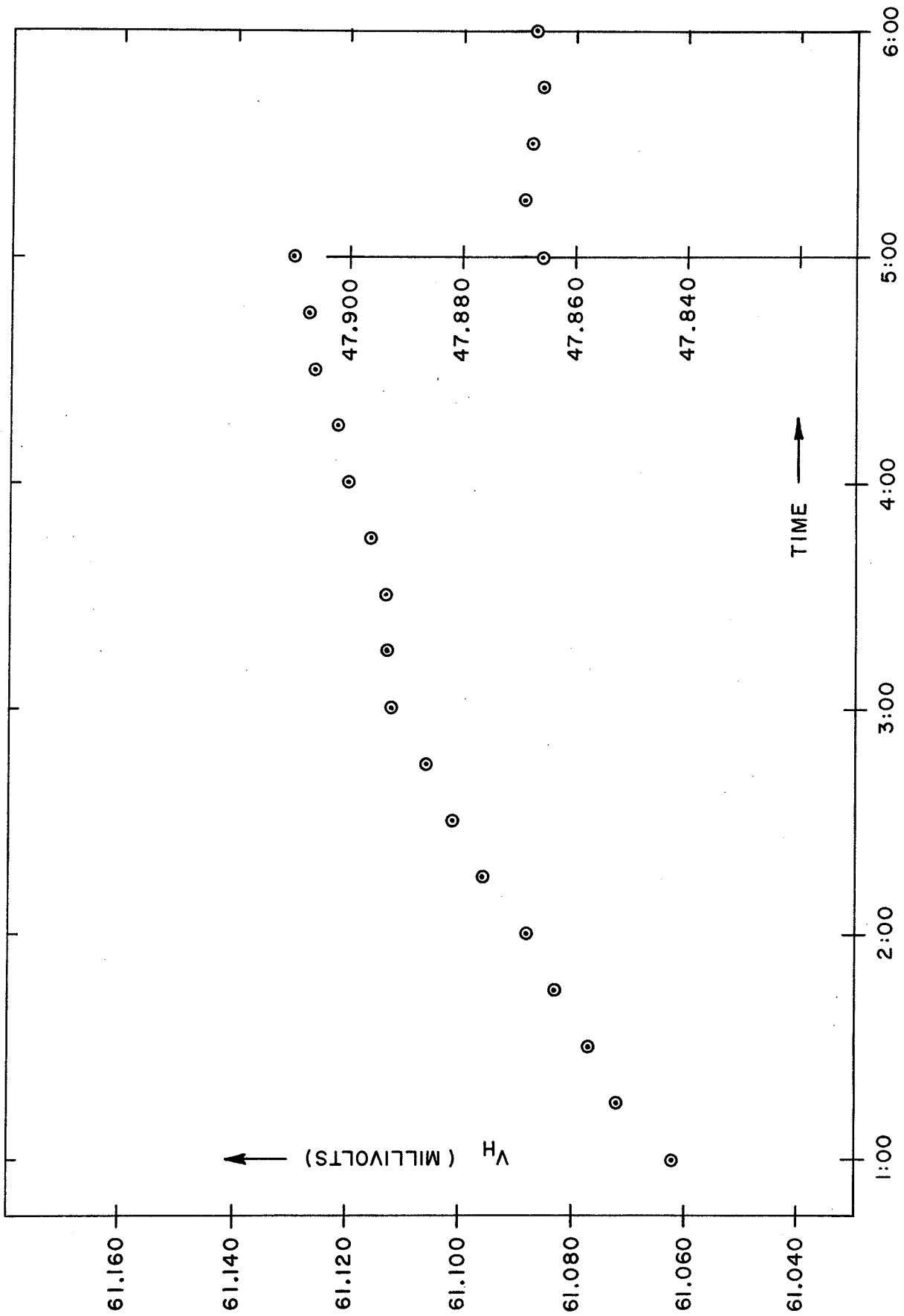

Fig. 17: Hall voltage vs. time for run #2.
 (Note change of scale at 5:00)

Permanent magnets are temperature-sensitive, with the magnetic field increasing with decreasing temperatures. The temperature coefficient of permanent magnets lies in the range -1 to $-5 \times 10^4 / ^\circ\text{C}$ and a representative value for an Alnico magnet is $-2 \times 10^{-4} / ^\circ\text{C}$ (Bozorth [11]). Using this last value, and assuming $\Delta T = -5^\circ\text{C}$, the change in field is

$$\Delta V = -2 \times 10^{-4} B \Delta T. \quad (29)$$

Numerically, this gives

$$\frac{\Delta B}{B} = -2 \times 10^{-4} \times -5 = +.001, \quad (30)$$

or a 0.1% increase in magnetic field. This is, of course, just the change observed in run #2. This explanation indicates that the drift of V_H in run #2 was probably the result of the temperature dependence of the magnet and not an inaccuracy of the Hall probe.

Recall from Chapter II that the temperature coefficient of the Hall constant was supposedly $0.04\% / ^\circ\text{C}$. This means that the temperature would have to change by about 0.25°C in order to produce a change of one part in 10^4 in V_H . Unfortunately, the manufacturer's specification was not met. To check this relationship experimentally, the temperature of the Hall probe was changed, and the corresponding change in V_H was observed. The results of this are shown in Fig. 18. The temperature was increased about 0.75°C , and

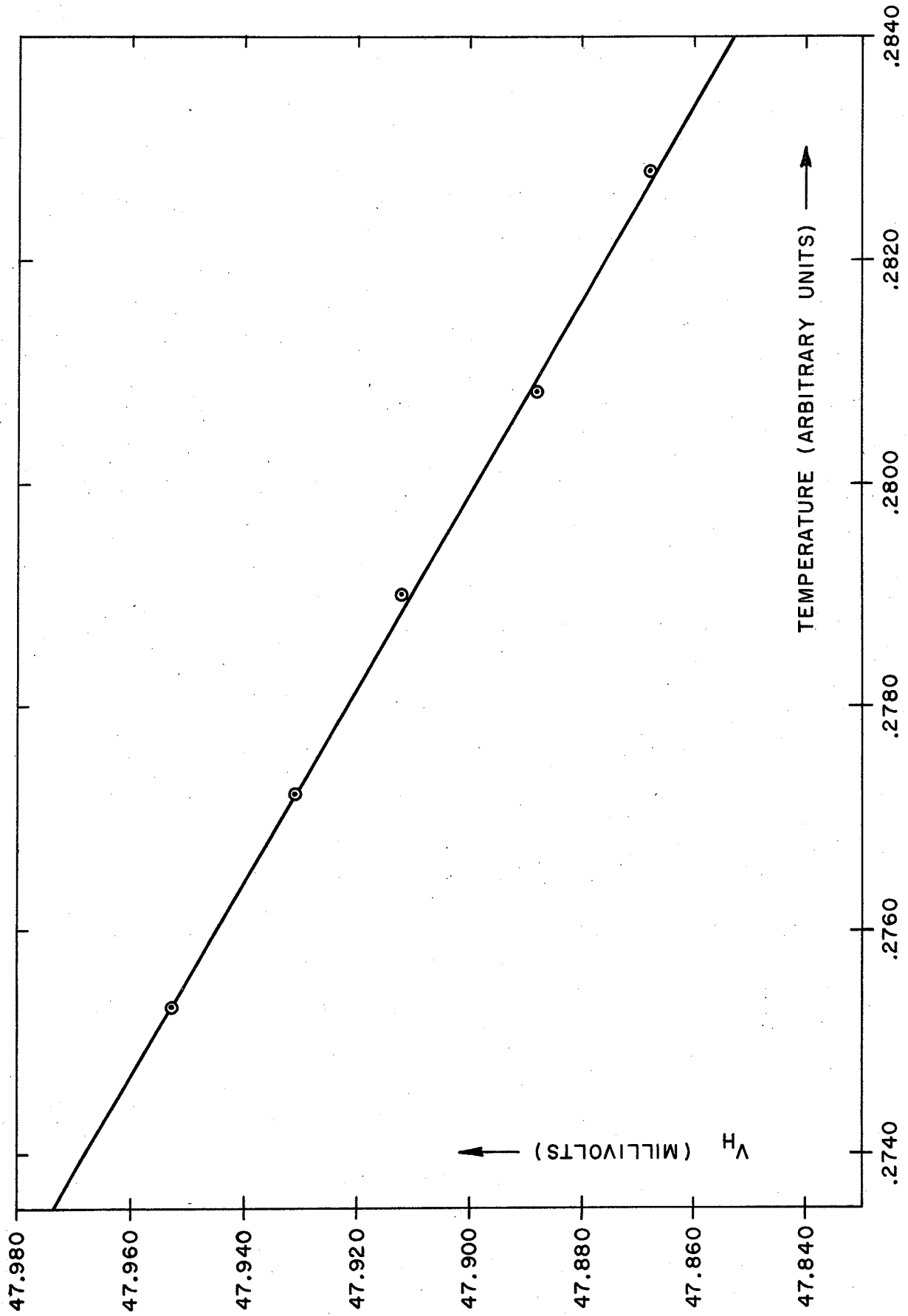

Fig. 18: Hall voltage as a function of probe temperature.

V_H decreased 85 parts out of 50,000. This gives a temperature coefficient of $0.2\%/^{\circ}\text{C}$ rather than $0.4\%/^{\circ}\text{C}$. It must be noted that this high temperature coefficient is probably the result of the damage inflicted on the probe, and not a lack of manufacturer quality control. Whereas previously it was assumed that a ΔT of 0.25°C could be allowed, the probe in its present condition must be maintained within a ΔT of 0.08°C . Fortunately, the temperature control system functions well enough to meet this requirement.

A final temperature effect was examined, and that is the dependence of temperature upon a changing magnetic field. The temperature was monitored on the digital voltmeter as the probe was inserted in the 1.4 kG permanent magnet. A momentary increase in temperature of about 0.01°C was observed, lasting about five seconds. The temperature then returned to its original value. Similarly, when the probe was removed from the magnet, the temperature increased 0.01° and again returned to normal. This sudden change of magnetic field, $\Delta B = 1.4 \text{ kG}$, presents a more severe condition than that which will be encountered in actual practice. Therefore, because the ΔT is several times smaller than the maximum allowable temperature variation, it follows that this temperature effect poses no difficulty.

Fig. 19 shows a graph of Hall voltage vs. magnetic

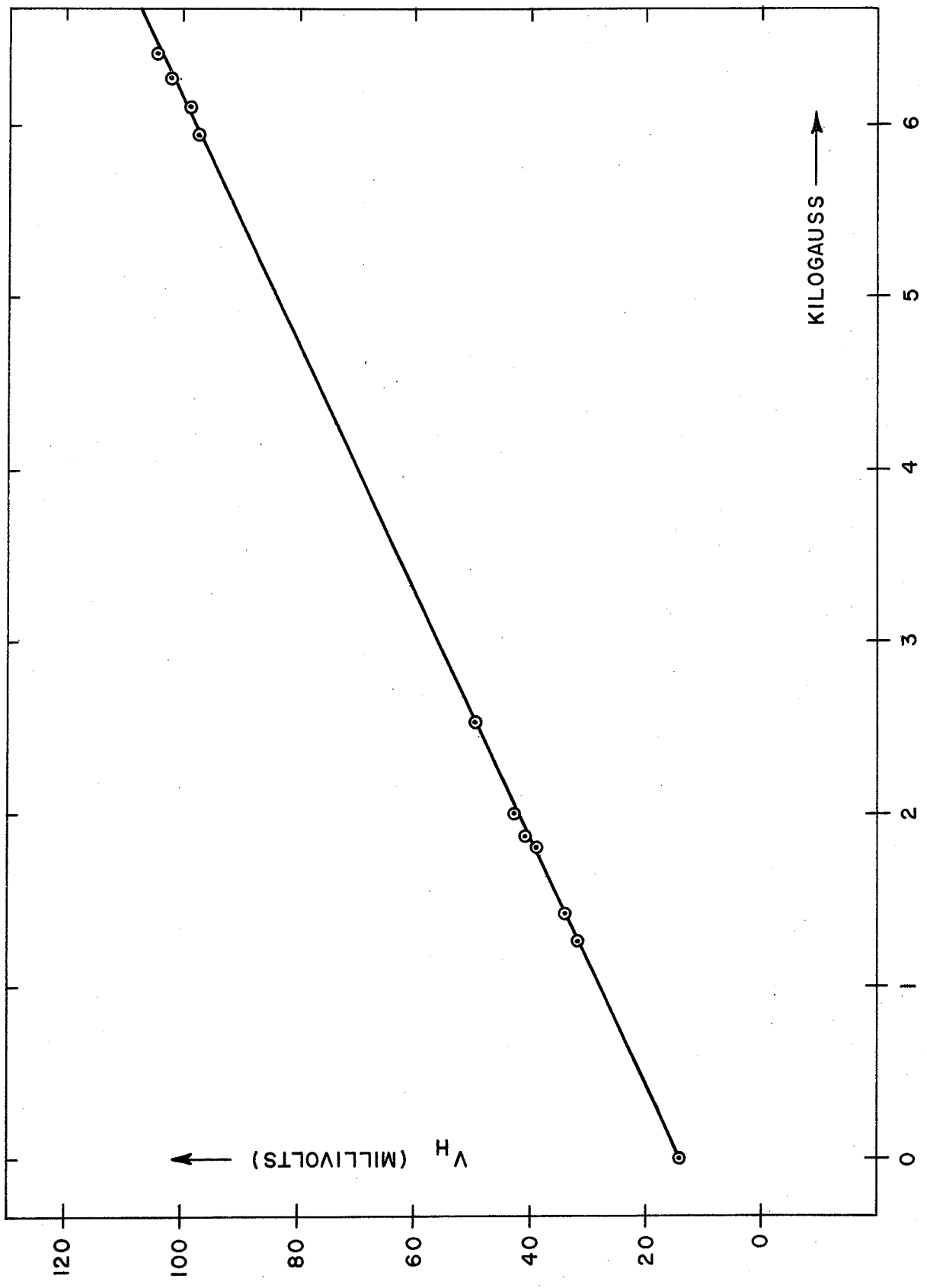

Fig. 19: Hall voltage vs. magnetic field.

field for fields up to 7 kG. A precise Varian magnet was used to produce the fields, the measurement of which was done with a proton magnetic resonance probe. One can see the very good linearity of the Hall probe over this range of fields. Although it is possible that at higher fields (up to 18 kG), some degree of non-linearity might occur, judging from known characteristics of Hall probes, it should be minimal.

VII. CONCLUSIONS

The main purpose of this research was to use thermo-electric coolers to provide temperature stability for a Hall effect fluxmeter. This was accomplished to a degree beyond original expectations. A short-term (an hour or so) temperature stability of 0.01°C will more than insure against any errors in the field readings due to temperature effects. Similarly, the Hall current supply appears to be an operational system.

The only questionable component is the Hall probe itself. Even in the case of the Hall probe, however, one must be optimistic. Although not entirely conclusive, it appears that the errors associated with the Hall probe were experimental inaccuracies rather than inherent limitations of the probe.

The state of the art of Hall probe fabrication has improved dramatically in the past few years and it seems likely that a new thin-film Hall probe will be used instead of the FC33. These new probes have a much higher output, higher input and output impedances, but at the same time, slightly larger temperature coefficients. However, with the

excellent temperature stability provided by the thermo-electric coolers, the high sensitivity of the new probes can be utilized.

REFERENCES

1. D. A. Lind, M. E. Rickey and M. M. Bardin, Magnetic field design and measurement for the Colorado 52 inch cyclotron. Sector-Focused Cyclotrons, North-Holland Publishing Co., Amsterdam, 1962.
2. J. H. Dorst, Full-scale magnetic measurements on the Berkeley 88-inch cyclotron. Sector-Focused Cyclotrons, North-Holland Publishing Co., Amsterdam, 1962.
3. E. D. Hudson, R. D. Lord, M. B. Marshall, W. R. Smith, and E. G. Richardson Jr., Achievement and measurement of the ORIC magnetic field. Sector-Focused Cyclotrons, North-Holland Publishing Co., Amsterdam, 1962.
4. C. Hilsum, British Journal of Applied Physics, 12, 85 (1961).
5. R. P. Chasmer, E. Cohen, Solid State Physics in Electronics and Telecommunications, 2, 659 (1960).
6. A. F. Ioffe, Physics of Semiconductors, Academic Press, New York, 1960.
7. H. J. Goldsmid, Applications of Thermoelectricity, John Wiley & Sons, New York, 1960.
8. C. R. Browning, private communication.
9. The epoxy is Eccoseal 1211, catalyst 9, Emerson and Cuming Inc.
10. B. D. Johnson, private communication.
11. R. M. Bozorth, Ferromagnetism, Van Nostrand Co., New York, 1951.